

**Note:** For the benefit of the students, specially the aspiring ones, the question of JEE(advanced), 2019 are also given in this booklet. Keeping the interest of students studying in class XI, the questions based on topics from class XI have been marked with ‘\*’, which can be attempted as a test. For this test the time allocated in Physics, Chemistry & Mathematics are 30 minutes, 21 minutes and 25 minutes respectively.

# FIITJEE

## SOLUTIONS TO JEE (ADVANCED) – 2019

### PART I: PHYSICS

#### Section 1 (maximum marks: 32)

- This section contains **EIGHT** (08) questions.
- Each question has **FOUR** options **ONE OR MORE THAN ONE** of these four option(s) is(are) correct answer(s).
- For each question, choose the option(s) corresponding to (all) the correct answer(s).
- Answer to each question will be evaluated according to the following marking scheme.
 

Full Marks	: +4	If only (all) the correct option(s) is (are) chosen;
Partial Marks	: +3	If all the four options are correct but <b>ONLY</b> three options are chosen;
Partial marks	: +2	if three or more options are correct but <b>ONLY</b> two options are chosen and both of which are correct;
Partial Marks	: +1	If two or more options are correct but <b>ONLY</b> one option is chosen and it is a correct option;
Zero Marks	: 0	If none of the options is chosen (i.e. the question is unanswered);
Negative Marks	: -1	In all other cases.
- For example, in a question, if (A), (B) and (D) are the **ONLY** three options corresponding to correct answers, then
  - choosing **ONLY** (A), (B) and (D) will get +4 marks;
  - choosing **ONLY** (A) and (B) will get +2 marks;
  - choosing **ONLY** (A) and (D) will get +2 marks;
  - choosing **ONLY** (B) and (D) will get +2 marks;
  - choosing **ONLY** (A) will get +1 marks;
  - choosing **ONLY** (B) will get +1 marks;
  - choosing **ONLY** (C) will get +1 marks;
  - choosing **ONLY** (D) will get +1 marks;
  - choosing no option (i.e. the question is unanswered) will get 0 marks; and
  - choosing any other combination of options will get -1 mark.

- Q.1 In a Young's double slit experiment, the slit separation  $d$  is 0.3 mm and the screen distance  $D$  is 1 m. A parallel beam of light of wavelength 600 nm is incident on the slits at angle  $\alpha$  as shown in figure. On the screen, the point  $O$  is equidistant from the slits and distance  $PO$  is 11.0 mm. Which of the following statements(s) is/are correct ?

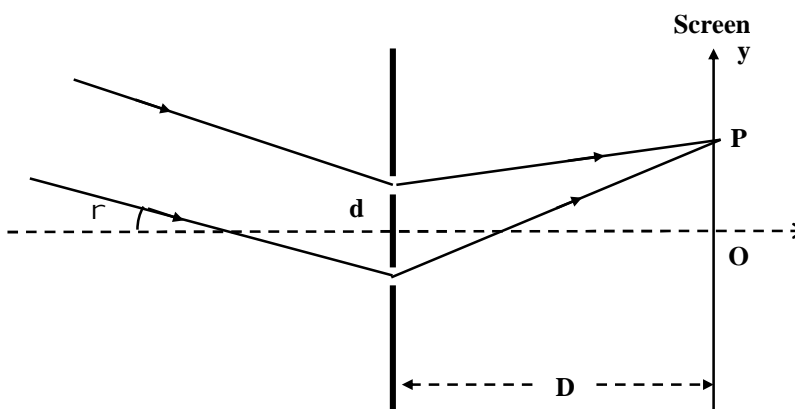

- A. For  $\alpha = \frac{0.36}{\pi}$  degree, there will be destructive interference at point O.
- B. Fringe spacing depends on  $\alpha$ .
- C. For  $\alpha = \frac{0.36}{\pi}$  degree, there will be destructive interference at point P.
- D. For  $\alpha = 0$ , there will be constructive interference at point P.

Sol. C

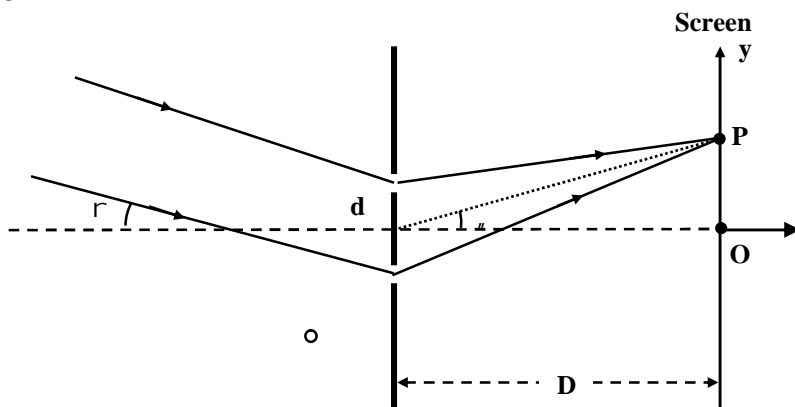

Given  $\alpha = \frac{0.36}{\pi}$  degree =  $\frac{1}{500}$  radian.

Path difference at O =  $d \sin \alpha = 0.3 \times 10^{-3} \times \frac{1}{500} = 6 \times 10^{-7} = \lambda$

Path difference at P =  $d(\sin \alpha + \sin \theta)$

=  $d \left( \frac{1}{500} + \frac{11}{1000} \right)$

=  $\frac{d}{500} \left( 1 + \frac{11}{2} \right)$

=  $\lambda(6.5)$

For  $\alpha = 0$ , path difference at P =  $5.5 \lambda$

∴ option C is correct

\*Q.2 A block of mass  $2M$  is attached to a massless spring with spring-constant  $k$ . This block is connected to two other blocks of masses  $M$  and  $2M$  using two massless pulleys and strings. The accelerations of the blocks are  $a_1$ ,  $a_2$  and  $a_3$  as shown in the figure. The system is released from rest with the spring in its unstretched state. The maximum extension of the spring is  $x_0$ . Which of the following option(s) is/are correct?

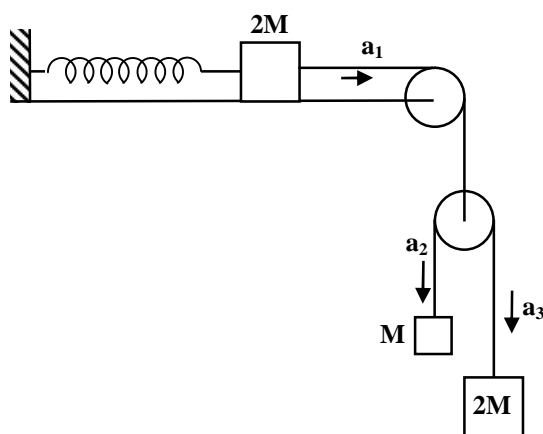

[ $g$  is the acceleration due to gravity. neglect friction]

- A.  $a_2 - a_1 = a_1 - a_3$
- B. At an extension of  $\frac{x_0}{4}$  of the spring, the magnitude of acceleration of the block connected to the spring is  $\frac{3g}{10}$

C.  $x_0 = \frac{4Mg}{k}$

D. When spring achieves an extension of  $\frac{x_0}{2}$  for the first time, the speed of the block connected to the spring is  $3g\sqrt{\frac{M}{5k}}$ .

Sol.

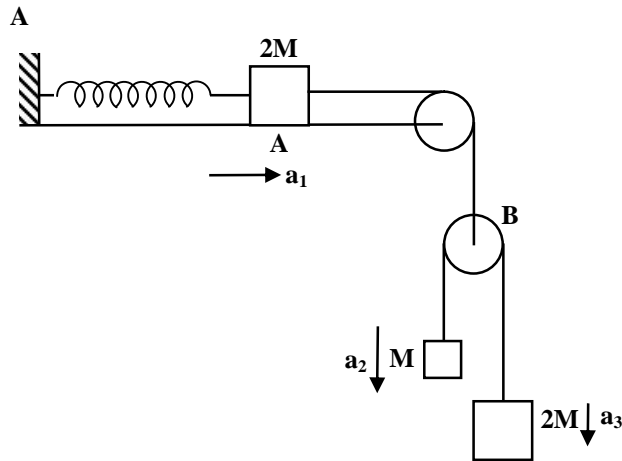

In the frame of pulley B, the hanging masses have accelerations :  
 $M \rightarrow (a_2 - a_1)$ ,  $2M \rightarrow (a_3 - a_1)$  : downward.  
 $\therefore (a_2 - a_1) = -(a_3 - a_1)$  [constant]  
 Assuming that the extension of the spring is  $x$   
 We consider the FBD of A :

$$2M \cdot \frac{d^2x}{dt^2} = 2T - kx$$

where  $a_1 \equiv \frac{d^2x}{dt^2}$  ... (i)

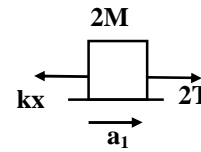

and the FBD of the rest of the system in the frame of pulley B :

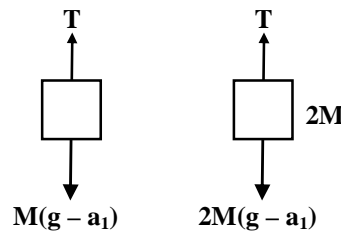

Upward acceleration of block M w.r.t. the pulley B = Downward acceleration of block 2M w.r.t the pulley

$$\frac{T - M(g - a_1)}{M} = \frac{2M(g - a_1) - T}{2M}$$

$$\Rightarrow T = \frac{4M}{3}(g - a_1) \quad \dots(ii)$$

substituting in equation (i), we get

$$2M \cdot a_1 = \frac{8M}{3}(g - a_1) - kx$$

$$\text{or } \frac{14M}{3}a_1 = \frac{8Mg}{3} - kx \quad \dots(\text{iii})$$

This is the equation of SHM

Maximum extension =  $2 \times$  Amplitude

$$\text{i.e. } x_0 = 2 \times \frac{8Mg}{3k}$$

At  $\frac{x_0}{4}$ , acceleration is easily found from equation (iii):

$$\frac{14M}{3}a_1 = \frac{8Mg}{3} - \frac{4Mg}{3}$$

$$a_1 = \frac{2g}{7}$$

At  $\frac{x_0}{2}$ , speed of the block ( $2M$ ) =  $\omega \times$  amplitude

$$= \sqrt{\frac{3k}{14M}} \times \frac{8Mg}{3k}$$

$\therefore$  option (A) is correct

\*Q.3 A thin and uniform rod of mass  $M$  and length  $L$  is held vertical on a floor with large friction. The rod is released from rest so that it falls by rotating about its contact-point with the floor without slipping. Which of the following statement(s) is/are correct, when the rod makes an angle  $60^\circ$  with vertical? [ $g$  is the acceleration due to gravity]

- A. The radial acceleration of the rod's center of mass will be  $\frac{3g}{4}$
- B. The angular speed of the rod will be  $\sqrt{\frac{3g}{2L}}$
- C. The angular acceleration of the rod will be  $\frac{2g}{L}$
- D. The normal reaction force from the floor on the rod will be  $\frac{Mg}{16}$

**Sol.** A, B, D

To find  $\omega$ , we apply COE :  $\frac{1}{2} \left( \frac{1}{3} ML^2 \right) \omega^2 = Mg \frac{L}{2} (1 - \cos 60^\circ)$

$$\omega = \sqrt{\frac{3g}{2L}}$$

$$a_{\text{CM, radial}} = \omega^2 \frac{L}{2} = \frac{3g}{4}$$

To find  $\alpha$ , we take torque about A :

$$Mg \frac{L}{2} \sin 60^\circ = \frac{1}{3} ML^2 \alpha$$

$$\text{so, } \alpha = \frac{3g}{2L} \sin 60^\circ$$

$$a_{\text{cm, tan g}} = \alpha \frac{L}{2} = \frac{3g}{4} \sin 60^\circ$$

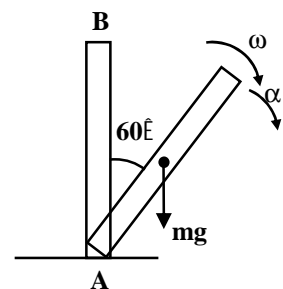

$$\therefore Mg - N = (a_{\text{cm,radial}} \cos 60^\circ + a_{\text{cm,tang}} \sin 60^\circ)$$

$$= M \left( \frac{3g}{8} + \frac{9g}{16} \right)$$

$$\therefore N = \frac{Mg}{16}$$

$\therefore$  Correct options are A, B, D

- \*Q.4 A small particle of mass  $m$  moving inside a heavy, hollow and straight tube along the tube axis undergoes elastic collision at two ends. The tube has no friction and it is closed at one end by a flat surface while the other end is fitted with a heavy movable flat piston as shown in figure. When the distance of the piston from closed end is  $L = L_0$  the particle speed is  $v = v_0$ . The piston is moved inward at a very low speed  $V$  such that  $V \ll \frac{dL}{L} v_0$ , where  $dL$  is the infinitesimal displacement of the piston. which of the following statement(s) is/are correct ?

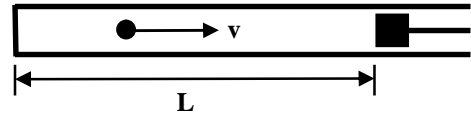

- A. The particle's kinetic energy increases by a factor of 4 when the piston is moved inward from  $L_0$  to  $\frac{1}{2}L_0$ .
- B. After each collision with the piston, the particle speed increases by  $2V$ .
- C. If the piston moves inward by  $dL$ , the particle speed increases by  $2v \frac{dL}{L}$ .
- D. The rate at which the particle strikes the piston is  $v/L$ .

Sol.

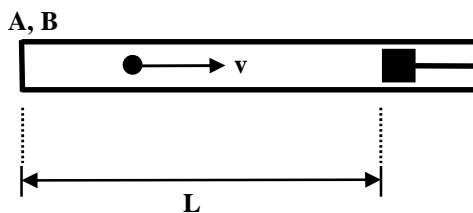

The rate of collision of the particle with the piston is  $\frac{1}{2L/v} = \frac{v}{2L}$

The speed of the particle after a collision with the piston is :

$v + 2V$ , when it collides with it with a speed  $v$ .

if the piston moves inward by  $dL$  the speed of the particle increases by

$$dv = 2V \times \frac{dL}{L} \times \frac{v}{2L}$$

$$\text{i.e. } \frac{dv}{v} = \frac{dL}{L}$$

Since kinetic energy,  $K = \frac{1}{2} mv^2$ ,  $\frac{dK}{K} = \frac{2(-dL)}{L}$  (after putting the proper sign)

Integrating,  $KL^2 = \text{constant}$ .

$$\therefore K_f = 4K_i$$

Hence correct options are A, B

- Q.5 Three glass cylinders of equal height  $H = 30$  cm and same refractive index  $n = 1.5$  are placed on a horizontal surface as shown in figure. Cylinder I has a flat top, cylinder II has a convex top and cylinder III has a concave top. The radii of curvature of the two curved tops are same ( $R = 3$  m). If  $H_1$ ,  $H_2$  and  $H_3$  are the apparent depths of a point X on the bottom of the three cylinders, respectively, the correct statement(s) is/are:

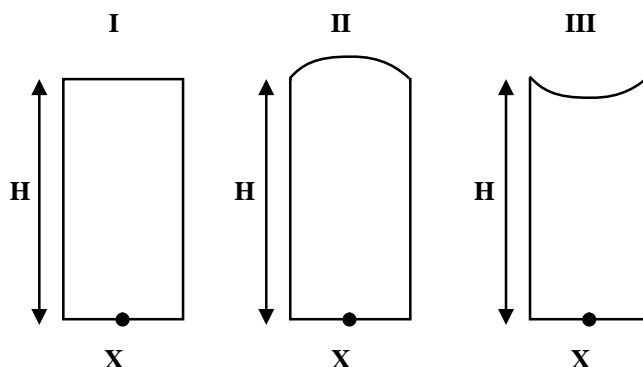

- A.  $H_2 > H_1$   
 B.  $H_2 > H_3$   
 C.  $H_3 > H_1$   
 D.  $0.8 \text{ cm} < (H_2 - H_1) < 0.9 \text{ cm}$

Sol. A, B

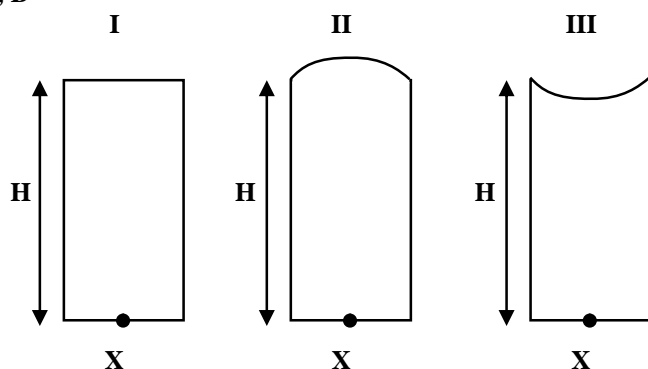

We apply,  $\frac{\mu_2}{v} - \frac{\mu_1}{u} = \frac{\mu_2 - \mu_1}{R}$ .

$$\frac{1}{-H_1} - \frac{1.5}{-30} = \frac{1-1.5}{\infty} \quad \dots(i)$$

$$\Rightarrow H_1 = 20 \text{ cm}$$

$$\frac{1}{-H_2} - \frac{1.5}{-30} = \frac{-0.5}{-300} \quad \dots(ii)$$

$$\Rightarrow H_2 = \frac{300}{14.5} \text{ cm}$$

$$\frac{1}{-H_3} - \frac{1.5}{-30} = \frac{-0.5}{300} \quad \dots(iii)$$

$$\Rightarrow H_3 = \frac{300}{15.5} \text{ cm}$$

$\therefore$  (A) and (B) are correct.

- Q.6 An electric dipole with dipole moment  $\frac{P_0}{\sqrt{2}}(\hat{i} + \hat{j})$  is held fixed at the origin O in the presence of a uniform electric field of magnitude  $E_0$ . If the potential is constant on a circle of radius R centered at the origin as shown in figure, then the correct statement(s) is/are : ( $\epsilon_0$  is permittivity of free space.  $R \gg$  dipole size)

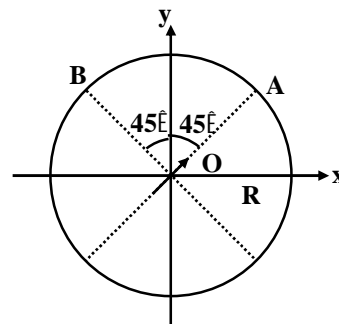

- A. Total electric field at point A is  $\vec{E}_A = \sqrt{2}E_0(\hat{i} + \hat{j})$   
 B. Total electric field at point B is  $\vec{E}_B = 0$   
 C.  $R = \left(\frac{P_0}{4\pi\epsilon_0 E_0}\right)^{1/3}$   
 D. The magnitude of total electric field on any two points of the circle will be same.

**Sol. B, C**

At B,  $\vec{E}$  due to dipole is tangential

$\Rightarrow$  The other field must at least cancel this  $\vec{E}$  due to dipole.

Also, at B, if the other field also had a component in radial direction, then this component would contribute to the net tangential component at A (since the other field is given to be uniform), which is not allowed since the given sphere is equipotential.

$$\Rightarrow \vec{E}_{\text{other}} = \frac{1}{4\pi\epsilon_0} \frac{P_0}{R^3} \left\{ \frac{\hat{i} + \hat{j}}{\sqrt{2}} \right\}$$

$\therefore$  (B) and (C) only

- Q.7 A free hydrogen atom after absorbing a photon of wavelength  $\lambda_a$  gets excited from the state  $n = 1$  to the state  $n = 4$ . Immediately after that the electron jumps to  $n = m$  state by emitting a photon of wavelength  $\lambda_e$ . Let the change in momentum of atom due to the absorption and the emission are  $\Delta p_a$  and  $\Delta p_e$  respectively. If  $\frac{\lambda_a}{\lambda_e} = \frac{1}{5}$ , which of the option(s) is /are correct ?

[Use  $hc = 1242 \text{ eV nm}$ ;  $1 \text{ nm} = 10^{-9} \text{ m}$ ,  $h$  and  $c$  are Planck's constant and speed of light, respectively]

- A.  $\frac{\Delta p_a}{\Delta p_e} = \frac{1}{2}$   
 B. The ratio of kinetic energy of the electron in the state  $n = m$  to the state  $n = 1$  is  $\frac{1}{4}$   
 C.  $\lambda_e = 418 \text{ nm}$   
 D.  $m = 2$

**Sol. B, D**

The energy level diagram is shown in the figure

$$\text{It is given : } \frac{\lambda_a}{\lambda_e} = \frac{1}{5}$$

$$\text{or, } \frac{\left(\frac{1}{m^2} - \frac{1}{4^2}\right)}{\left(1 - \frac{1}{4^2}\right)} = \frac{\frac{1}{\lambda_e}}{\frac{1}{\lambda_a}} = \frac{1}{5}$$

$$\Rightarrow m = 2$$

$$\text{clearly } \frac{\Delta p_a}{\Delta p_e} \neq \frac{1}{2}$$

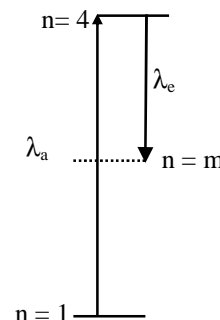

The ratio of the kinetic energies is also the ratio of the corresponding total energies =  $\frac{1}{4}$

$\therefore$  correct options are B, D

- \*Q.8 A mixture of ideal gas contains 5 moles of monatomic gas and 1 mole of rigid diatomic gas is initially at pressure  $P_0$ , volume  $V_0$ , and temperature  $T_0$ . If the gas mixture is adiabatically compressed to a volume  $\frac{V_0}{4}$ , then the correct statement(s) is/are, (Given  $2^{1.2} = 2.3$ ;  $2^{3.2} = 9.2$ ; R is gas constant)
- Adiabatic constant of the gas mixture is 1.6
  - The final pressure of the gas mixture after compression is in between  $9P_0$  and  $10P_0$
  - The work  $|W|$  done during the process is  $13RT_0$
  - The average kinetic energy of the gas mixture after compression is in between  $18RT_0$  and  $19RT_0$ .

**Sol. A, B, C**

$$\frac{5+1}{\gamma_m - 1} = \frac{n_1}{\gamma_1 - 1} + \frac{n_2}{\gamma_2 - 1}$$

$$\Rightarrow \frac{6}{\gamma_m - 1} = \frac{5}{3-1} + \frac{1}{5-1} = 10$$

$$\gamma_m = 1.6$$

$$P_0 V_0^{\gamma_m} = P \left(\frac{V_0}{4}\right)^{\gamma_m} \Rightarrow P = P_0 \times 2^{3.2} = 9.2 P_0$$

$$W = \frac{P_0 V_0 - (9.2 P_0) \times \frac{V_0}{4}}{0.6} = \frac{-1.3 P_0 V_0}{0.6} = \frac{13}{6} 6RT_0 = 13RT_0$$

$$T_0 V_0^{\gamma_m - 1} = T V^{\gamma_m - 1} \Rightarrow T = T_0 \left(\frac{V_0}{V}\right)^{\gamma_m - 1} = T_0 (4)^{0.6} = 2.3 T_0$$

Average kinetic energy of the gas mixture

$$= 5 \times \frac{3}{2} RT + 1 \times \frac{5}{2} RT = 10RT = 23 RT_0$$

## Section 2 (Maximum Marks: 18)

- This section contains **SIX (06)** questions. The answer to each question is a **NUMERICAL VALUE**.
- For each question, enter the correct numerical value of the answer using the mouse and the on-screen virtual numeric keypad in the place designated to enter the answer. If the numerical value has more than two decimal places, **truncate/round-off** the value to **TWO** decimal places.
- Answer to each question will be evaluated according to the following marking scheme.  
Full Marks : +3 If only the correct numerical value is entered.  
Zero Marks : 0 In all other cases.

- Q.1 Suppose a  ${}^{226}_{88}\text{Ra}$  nucleus at rest and in ground state undergoes  $\alpha$ -decay to a  ${}^{222}_{86}\text{Rn}$  nucleus in its excited state. The kinetic energy of the emitted  $\alpha$  particle is found to be 4.44 MeV.  ${}^{222}_{86}\text{Rn}$  nucleus then goes to its ground state by  $\gamma$ -decay. The energy of the emitted  $\gamma$  photon is \_\_\_\_\_ keV.  
[Given: atomic mass of  ${}^{226}_{88}\text{Ra} = 226.005$  u, atomic mass of  ${}^{222}_{86}\text{Rn} = 222.000$  u, atomic mass of  $\alpha$  particle = 4.000 u,  $1 \text{ u} = 931 \text{ MeV}/c^2$ ,  $c$  is speed of the light]

Sol. **135.00**

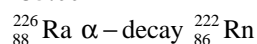

$$\text{Total energy emitted} = (\Delta m)c^2$$

$$= 0.005 \times 931.5 \text{ MeV} = E_0 \text{ (say)} \quad \dots\text{(i)}$$

$$\text{Also, } E_\alpha = 4.44 \text{ MeV} \quad \dots\text{(ii)}$$

$$E_{\text{Rn}} = 4.44 \text{ MeV} \times \frac{4}{222} \quad \dots\text{(iii)}$$

$$\Rightarrow E_\gamma = E_0 - E_\alpha - E_{\text{Rn}} = 135 \text{ keV}$$

- \*Q.2 A ball is thrown from ground at an angle  $\theta$  with horizontal and with an initial speed  $u_0$ . For the resulting projectile motion, the magnitude of average velocity of the ball up to the point when it hits the ground for the first time is  $V_1$ . After hitting the ground, the ball rebounds at the same angle  $\theta$  but with a reduced speed of  $u_0/\alpha$ . Its motion continues for a long time as shown in figure. If the magnitude of average velocity of the ball for entire duration of motion is  $0.8 V_1$ , the value of  $\alpha$  is \_\_\_\_\_.

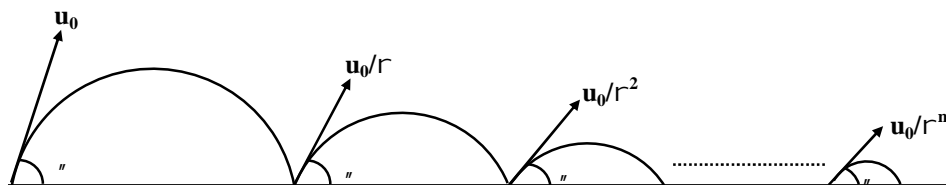

Sol. **4.00**

$$\text{Let } \frac{2u_0 \sin \theta}{g} = T_0 \text{ and } u_0 \cos \theta = v_1 \text{ (given)}$$

$$\text{Average velocity} = \frac{u_0 \cos \theta T_0 + \frac{u_0}{\alpha} \cos \theta \frac{T_0}{\alpha} + \frac{u_0}{\alpha^2} \cos \theta \frac{T_0}{\alpha^2}}{T_0 + \frac{T_0}{\alpha} + \frac{T_0}{\alpha^2} + \dots}$$

$$= \frac{u_0 \cos \theta T_0 \left( 1 + \frac{1}{\alpha^2} + \frac{1}{\alpha^4} + \dots \right)}{T_0 \left( 1 + \frac{1}{\alpha} + \frac{1}{\alpha^2} + \dots \right)} = v_1 \frac{\alpha}{\alpha + 1} = 0.8V_1$$

$$\alpha = 4$$

Q.3 A 10 cm long perfectly conducting wire PQ is moving with a velocity 1 cm/s on a pair of horizontal rails of zero resistance. One side of the rails is connected to an inductor  $L = 1$  mH and a resistance  $R = 1 \Omega$  as shown in the figure. The horizontal rails, L and R lie in the same plane with a uniform magnetic field  $B = 1$  T perpendicular to the plane. If the key S is closed at certain instant, the current in the circuit after 1 millisecond is  $x \times 10^{-3}$  A, where the value of x is \_\_\_\_\_.

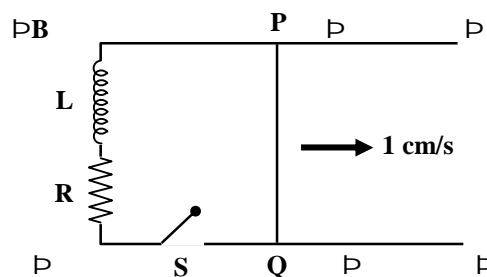

[Assume the velocity of wire PQ remains constant (1 cm/s) after key S is closed. Given:  $e^{-1} = 0.37$ , where e is base of the natural logarithm]

Sol. 0.63

$$I = \frac{\mathcal{E}}{R} (1 - e^{-Rt/L}) = \frac{Blv}{R} (1 - e^{-Rt/L})$$

$$= \frac{1 \times 0.1 \times 10^{-2}}{1} (1 - e^{-1 \times 10^{-3} / 10^{-3}}) = (1 - e^{-1}) = 0.63 \text{ mA}$$

Hence  $x = 0.63$

Q.4 A perfectly reflecting mirror of mass M mounted on a spring constitutes a spring-mass system of angular frequency  $\Omega$  such that  $\frac{4\pi M\Omega}{h} = 10^{24} \text{ m}^{-2}$  with h as Planck's constant. N photons of wavelength  $\lambda = 8\pi \times 10^{-6} \text{ m}$  strike the mirror simultaneously at normal incidence such that the mirror gets displaced by  $1 \mu\text{m}$ . If the value of N is  $x \times 10^{12}$ , then the value of x is \_\_\_\_\_.  
[Consider the spring as massless]

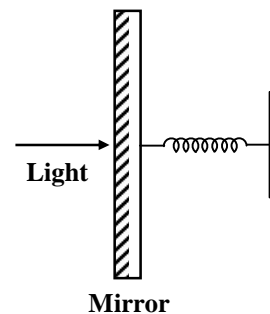

Sol. 1.00

If v is speed of mirror just after absorption of photons

$$Mv - N \frac{2h}{\lambda} = 0 \Rightarrow v = \frac{2Nh}{M\lambda}$$

If  $\ell$  is the maximum compression in the spring

$$\frac{1}{2} k\ell^2 = \frac{1}{2} mv^2$$

$$\Rightarrow v = \sqrt{\frac{k}{m}} \ell$$

$$\Rightarrow \frac{2Nh}{M\lambda} = \Omega \times 10^{-6}$$

$$\Rightarrow N = \Omega \times 10^{-6} \times \frac{M\lambda}{2h} = 8\pi \times 10^{-6} \times 10^{-6} \times \frac{M\lambda}{2h}$$

$$\frac{4\pi M\lambda}{h} \times 10^{-12} = 10^{24} \times 10^{-12} = 10^{12}$$

$$\Rightarrow x = 1$$

- Q.5 A monochromatic light is incident from air on a refracting surface of prism of angle  $75^\circ$  and refractive index  $n_0 = \sqrt{3}$ . The other refracting surface of the prism is coated by a thin film of material of refractive index  $n$  as shown in figure. The light suffers total internal reflection at the coated prism surface for an incidence angle of  $\theta \leq 60^\circ$ . The value of  $n^2$  is \_\_\_\_\_.

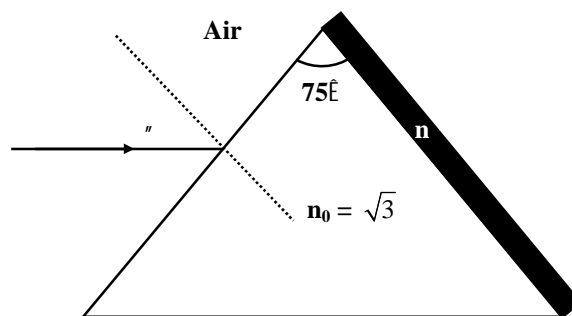

**Sol. 1.50**

When angle of incidence on first face of the prism is  $60^\circ$  the angle of incidence on the other surface of the prism will be slightly greater than critical angle.

For refraction at first surface of the prism

$$\sin 60^\circ = \sqrt{3} \sin r_1$$

$$\Rightarrow r_1 = 30^\circ$$

For second surface  $r_2 = 75^\circ - 30^\circ = 45^\circ$

Since  $r_2 \approx \theta_c$

$$\Rightarrow \sin 45^\circ = \frac{n}{\sqrt{3}}$$

$$\Rightarrow n^2 = 1.50$$

- Q.6 An optical bench has 1.5 m long scale having four equal divisions in each cm. While measuring the focal length of a convex lens, the lens is kept at 75 cm mark of the scale and the object pin is kept at 45 cm mark. The image of the object pin on the other side of the lens overlaps with image pin that is kept at 135 cm mark. In this experiment, the percentage error in the measurement of the focal length of the lens is \_\_\_\_\_.

**Sol. 1.39**

$$\frac{1}{v} - \frac{1}{-u} = \frac{1}{f}$$

$$\Rightarrow \frac{\Delta v}{v^2} + \frac{\Delta u}{u^2} = \frac{\Delta f}{f^2}$$

% error in the measurement of focal length

$$= \frac{\Delta f}{f} \times 100 = \left( \frac{\Delta v}{v^2} + \frac{\Delta u}{u^2} \right) \times f \times 100$$

$$= \left[ \frac{0.5}{(60)^2} + \frac{0.5}{(30)^2} \right] \times 20 \times 100 = 1.39$$

## Section 3 (Maximum Marks: 12)

- This section contains **TWO (02)** List-Match Sets.
- Each List-Match set has **TWO(02)** Multiple Choice Questions.
- Each List-Match set has two lists: **List-I** and **List-II**.
- **List-I** has **Four** entries (I), (II), (III) and (IV) and **List-II** has **Six** entries (P), (Q), (R), (S), (T) and (U).
- **FOUR** options are given in each Multiple Choice Question based On **List-I** and **List-II** and **ONLY ONE** of these four options satisfies the condition asked in the Multiple Choice Question.
- Answer to each question will be evaluated according to the following marking scheme:  
Full Marks : +3 If **ONLY** the option corresponding to correct combination is chosen;  
Zero Marks : 0 If none of the options is chosen (i.e., the question is unanswered);  
Zero Marks : -1 In all other cases.

Answer the following by appropriately matching the list based on the information given in the paragraph.

A musical instrument is made using four different metal strings, 1, 2, 3 and 4 with mass per unit length  $\mu$ ,  $2\mu$ ,  $3\mu$  and  $4\mu$  respectively. The instrument is played by vibrating the strings by varying the free length in between the range  $L_0$  and  $2L_0$ . It is found that in string-1( $\mu$ ) at free length  $L_0$  and tension  $T_0$  the fundamental mode frequency is  $f_0$ .

List –I gives the above four strings while list –II lists the magnitude of some quantity.

List-I	List-II
(I) String-1 ( $\mu$ )	(P) 1
(II) String-2 ( $2\mu$ )	(Q) $1/2$
(III) String-3 ( $3\mu$ )	(R) $1/\sqrt{2}$
(IV) String-4 ( $4\mu$ )	(S) $1/\sqrt{3}$
	(T) $3/16$
	(U) $1/16$

- \*Q.1 If the tension in each string is  $T_0$ , the correct match for the highest fundamental frequency in  $f_0$  units will be,

**Options**

- A. I  $\rightarrow$  P, II  $\rightarrow$  R, III  $\rightarrow$  S, IV  $\rightarrow$  Q  
 B. I  $\rightarrow$  Q, II  $\rightarrow$  S, III  $\rightarrow$  R, IV  $\rightarrow$  P  
 C. I  $\rightarrow$  P, II  $\rightarrow$  Q, III  $\rightarrow$  T, IV  $\rightarrow$  S  
 D. I  $\rightarrow$  Q, II  $\rightarrow$  P, III  $\rightarrow$  R, IV  $\rightarrow$  T

**Sol.** A

$$f_0 = \frac{1}{2L_0} \sqrt{\frac{T_0}{\mu}}$$

$$f_1 = \frac{1}{2L_0} \sqrt{\frac{T_0}{2\mu}} = \frac{f_0}{\sqrt{2}}$$

$$f_2 = \frac{1}{2L_0} \sqrt{\frac{T_0}{3\mu}} = \frac{f_0}{\sqrt{3}}$$

$$f_4 = \frac{1}{2L_0} \sqrt{\frac{T_0}{4\mu}} = \frac{f_0}{2}$$

- \*Q.2 The length of the string 1, 2, 3 and 4 are kept fixed at  $L_0$ ,  $\frac{3L_0}{2}$ ,  $\frac{5L_0}{4}$  and  $\frac{7L_0}{4}$ , respectively. Strings 1, 2, 3 and 4 are vibrated at their 1<sup>st</sup>, 3<sup>rd</sup>, 5<sup>th</sup> and 14<sup>th</sup> harmonics, respectively such that all the strings have same frequency. The correct match for the tension in the four strings in the units of  $T_0$  will be,

**Options**

- A. I  $\rightarrow$  P, II  $\rightarrow$  Q, III  $\rightarrow$  T, IV  $\rightarrow$  U  
 B. I  $\rightarrow$  P, II  $\rightarrow$  Q, III  $\rightarrow$  R, IV  $\rightarrow$  T  
 C. I  $\rightarrow$  P, II  $\rightarrow$  R, III  $\rightarrow$  T, IV  $\rightarrow$  U  
 D. I  $\rightarrow$  T, II  $\rightarrow$  Q, III  $\rightarrow$  R, IV  $\rightarrow$  U

**Sol. A**

$$f_0 = \frac{1}{2L_0} \sqrt{\frac{T_0}{\mu}}$$

For string -2

$$\frac{3}{2 \times \frac{3L_0}{2}} \sqrt{\frac{T_2}{2\mu}} = \frac{1}{2L_0} \sqrt{\frac{T_0}{\mu}}$$

$$T_2 = \frac{T_0}{2}$$

For string -3

$$\frac{5}{2 \times \frac{5L_0}{4}} \sqrt{\frac{T_3}{3\mu}} = \frac{1}{2L_0} \sqrt{\frac{T_0}{\mu}}$$

$$T_3 = \frac{3T_0}{16}$$

For string -4

$$\frac{14}{2 \times \frac{7L_0}{4}} \sqrt{\frac{T_4}{4\mu}} = \frac{1}{2L_0} \sqrt{\frac{T_0}{\mu}}$$

$$T_4 = \frac{T_0}{16}$$

Answer the following by appropriately matching the list based on the information given in the paragraph.

In a thermodynamic process on an ideal monatomic gas, the infinitesimal heat absorbed by the gas is given by  $T\Delta X$ , where  $T$  is temperature of the system and  $\Delta X$  is the infinitesimal change in a thermodynamic

quantity  $X$  of the system. For a mole of monatomic ideal gas  $X = \frac{3}{2}R \ln\left(\frac{T}{T_A}\right) + R \ln\left(\frac{V}{V_A}\right)$ . Here,  $R$  is gas

constant,  $V$  is volume of gas.  $T_A$  and  $V_A$  are constants.

The List –I below gives some quantities involved in a process and List –II gives some possible values of these quantities.

List-I	List-II
(I) Work done by the system in process $1 \rightarrow 2 \rightarrow 3$	(P) $\frac{1}{3}RT_0 \ln 2$
(II) Change in internal energy in process $1 \rightarrow 2 \rightarrow 3$	(Q) $\frac{1}{3}RT_0$
(III) Heat absorbed by the system in process $1 \rightarrow 2 \rightarrow 3$	(R) $RT_0$
(IV) Heat absorbed by the system in process $1 \rightarrow 2$	(S) $\frac{4}{3}RT_0$
	(T) $\frac{1}{3}RT_0(3 + \ln 2)$
	(U) $\frac{5}{6}RT_0$

\*Q.3 If the process carried out on one mole of monatomic ideal gas is as shown in figure in the PV-diagram with

$P_0V_0 = \frac{1}{3}RT_0$ , the correct match is,

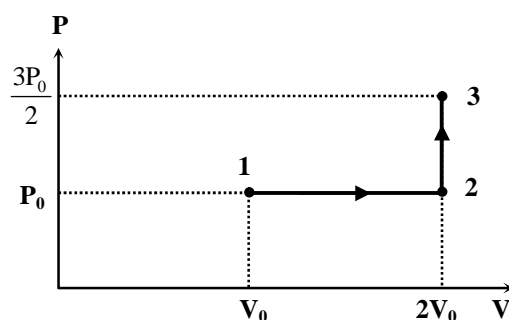

#### Options

- A. I  $\rightarrow$  Q, II  $\rightarrow$  R, III  $\rightarrow$  S, IV  $\rightarrow$  U  
 B. I  $\rightarrow$  Q, II  $\rightarrow$  S, III  $\rightarrow$  R, IV  $\rightarrow$  U  
 C. I  $\rightarrow$  Q, II  $\rightarrow$  R, III  $\rightarrow$  P, IV  $\rightarrow$  U  
 D. I  $\rightarrow$  S, II  $\rightarrow$  R, III  $\rightarrow$  Q, IV  $\rightarrow$  T

**Sol.** A

$$W_{1 \rightarrow 2 \rightarrow 3} = P_0V_0 = \frac{1}{3}RT_0$$

$$\Delta U_{1 \rightarrow 2 \rightarrow 3} = nC_V(T_f - T_i) = 1 \times \frac{3}{2}(3P_0V_0 - P_0V_0) = RT_0$$

$$\Delta Q_{1 \rightarrow 2 \rightarrow 3} = \Delta U + W = \frac{4}{3}RT_0$$

$$\Delta Q_{1 \rightarrow 2} = nC_P\Delta T = \frac{5}{2}(2P_0V_0 - P_0V_0) = \frac{5}{6}RT_0$$

- \*Q.4 If the process on one mole of monatomic ideal gas is as shown in the TV-diagram with  $P_0V_0 = \frac{1}{3}RT_0$ , the correct match is,

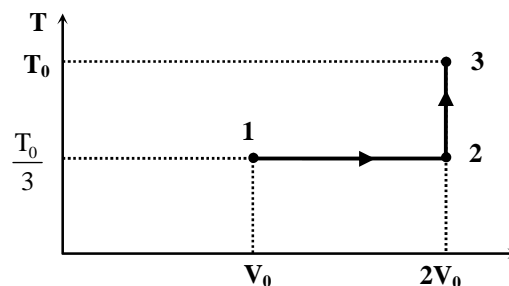

**Options**

- A. I  $\rightarrow$  P, II  $\rightarrow$  T, III  $\rightarrow$  Q, IV  $\rightarrow$  T  
 B. I  $\rightarrow$  S, II  $\rightarrow$  T, III  $\rightarrow$  Q, IV  $\rightarrow$  U  
 C. I  $\rightarrow$  P, II  $\rightarrow$  R, III  $\rightarrow$  T, IV  $\rightarrow$  S  
 D. I  $\rightarrow$  P, II  $\rightarrow$  R, III  $\rightarrow$  T, IV  $\rightarrow$  P

**Sol. D**

$$W_{1 \rightarrow 2 \rightarrow 3} = W_{1 \rightarrow 2} + W_{2 \rightarrow 3} = R \frac{T_0}{3} \ln \frac{2V_0}{V_0} + 0 = \frac{RT_0}{3} \ln 2$$

$$\Delta U_{1 \rightarrow 2 \rightarrow 3} = \Delta U_{1 \rightarrow 2} + \Delta U_{2 \rightarrow 3} = 0 + nC_v \left( T_0 - \frac{T_0}{3} \right)$$

$$= 0 + 1 \times \frac{3R}{2} \times \frac{2T_0}{3} = RT_0$$

$$\Delta Q_{1 \rightarrow 2} = \int T dx = \int T \left( \frac{3R}{2T} dT + \frac{R}{2} dV \right) = \frac{3R}{2} \int dT + \int_{V_0}^{2V_0} \frac{RT}{V} dV = 0 + RT \ln 2$$

$$\Delta Q_{2 \rightarrow 3} = \int T dx = \frac{3R}{2} \int_{T_0/3}^{T_0} dT + \int \frac{RT}{V} dV = \frac{3R}{2} \times \frac{2T_0}{3} + 0 = RT_0$$

$$\Delta Q_{1 \rightarrow 2 \rightarrow 3} = RT \ln 2 + RT_0 = \frac{1}{3}RT_0(3 + \ln 2)$$

## PART II-CHEMISTRY

## SECTION 1 (Maximum Marks: 32)

This section contains **EIGHT (08)** questions.

• Each question has **FOUR** options for correct answer(s). **ONE OR MORE THAN ONE** of these four option(s) is (are) correct option(s).

• For each question, choose the option(s) corresponding to (all) the correct answer(s).

• Answer to each question will be evaluated according to the following marking scheme:

*Full Marks* : +4 If only (all) the correct option(s) is (are) chosen.

*Partial Marks* : +3 If all the four options are correct but **ONLY** three options are chosen.

*Partial Marks* : +2 If three or more options are correct but **ONLY** two options are chosen, both of which are correct options.

*Partial Marks* : +1 If two or more options are correct but **ONLY** one option is chosen and it is a correct option.

*Zero Marks* : 0 If none of the options is chosen (i.e. the question is unanswered).

*Negative Marks* : -1 In all other cases.

• **For Example:** in a question, If (A), (B) and (D) are the **ONLY** three options corresponding to correct answers, then choosing **ONLY** (A), (B) and (D) will get +4 marks;

choosing **ONLY** (A) and (B) will get +2 marks;

choosing **ONLY** (A) and (D) will get +2 marks;

choosing **ONLY** (B) and (D) will get +2 marks;

choosing **ONLY** (A) will get +1 mark;

choosing **ONLY** (B) will get +1 mark;

choosing **ONLY** (D) will get +1 mark;

Choosing no option (i.e. the question is unanswered) will get 0 marks; and choosing any other combination of options will get - 1 mark.

\*Q.1. Choose the correct option(s) that give(s) an aromatic compound as the major product

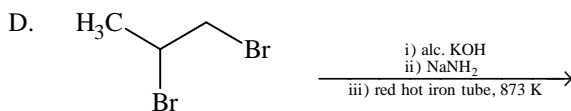
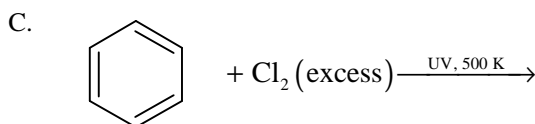
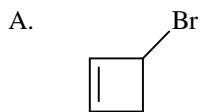

Sol. B, D  
(B)

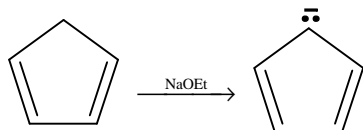

(D)

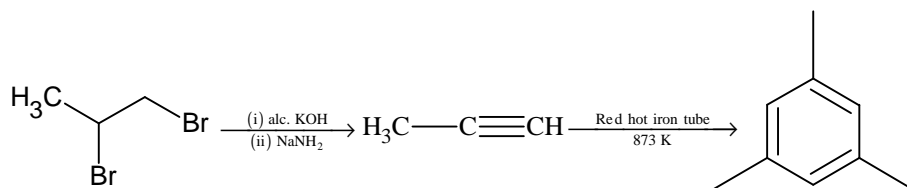

2. Consider the following reactions (unbalanced)

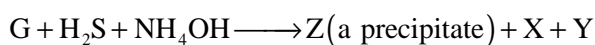
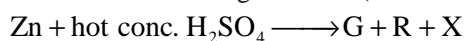

Choose the correct option(s)

- A. The oxidation state of Zn in T is +1
- B. R is a V-shaped molecule
- C. Z is dirty white in colour
- D. Bond order of Q is 1 in its ground state

Sol. B, C, D

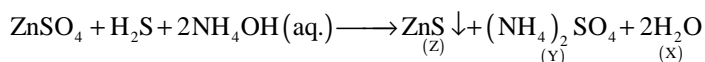
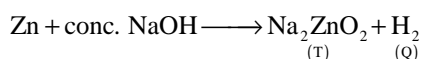
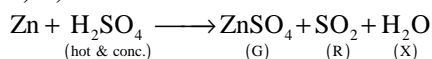

\*Q.3. Which of the following reactions produce(s) propane as a major product?

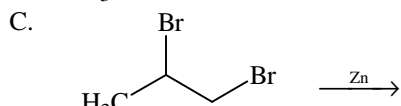
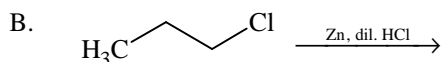
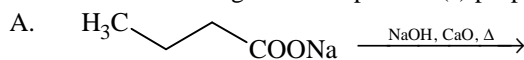

Sol. A, B

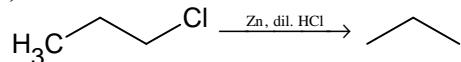

4. Choose the correct option(s) from the following:

- A. Cellulose has only  $\alpha$ -D-glucose units that are joined by glycosidic linkages
- B. Teflon is prepared by heating tetrafluoroethene in presence of a persulphate catalyst at high pressure
- C. Natural rubber is polyisoprene containing *trans* alkene units
- D. Nylon-6 has amide linkages

Sol. B, D

\*Q.5. The ground state energy of hydrogen atom is  $-13.6$  eV. Consider an electronic state  $\psi$  of  $\text{He}^+$  whose energy, azimuthal quantum number and magnetic quantum number are  $-3.4$  eV, 2 and 0, respectively. Which of the following statement(s) is(are) true for the state  $\psi$  ?

- A. It is a 4d state
- B. It has 2 angular nodes
- C. It has 3 radial nodes
- D. The nuclear charge experienced by the electron in this state is less than  $2e$ , where  $e$  is the magnitude of the electronic charge

Sol. **A, B**

$$-3.4 = \frac{-13.6 \times 2^2}{n^2}$$

$$n = 4$$

$$\ell = 2$$

Subshell = 4d

Angular nodes =  $\ell = 2$

Radial nodes =  $n - \ell - 1 = 4 - 2 - 1 = 1$

6. The cyanide process of gold extraction involves leaching out gold from its ore with  $\text{CN}^-$  in the presence of Q in water to form R. Subsequently, R is treated with T to obtain Au and Z. Choose the correct option(s)

- A. Z is  $[\text{Zn}(\text{CN})_4]^{2-}$
- B. T is Zn
- C. R is  $[\text{Au}(\text{CN})_2]^-$
- D. Q is  $\text{O}_2$

Sol. **A, B, D**

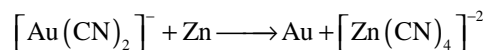
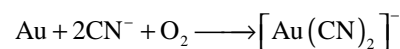
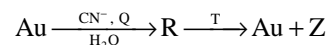

7. With reference to *aqua regia*, choose the correct option(s)

- A. The yellow colour of *aqua regia* is due to the presence of  $\text{NOCl}$  and  $\text{Cl}_2$
- B. *Aqua regia* is prepared by mixing conc.  $\text{HCl}$  and conc.  $\text{HNO}_3$  in 3 : 1 (v/v) ratio
- C. Reaction of gold with *aqua regia* produces an anion having Au in +3 oxidation state
- D. Reaction of gold with *aqua regia* produces  $\text{NO}_2$  in the absence of air

Sol. **A, C**

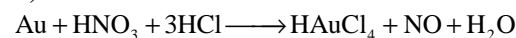

Yellow colour of aqua – regia is due to  $\text{NOCl}$  and  $\text{Cl}_2$ .

In aqua regia  $\text{HCl}$  and  $\text{HNO}_3$  are in 3:1 molar ratio

8. Choose the correct option(s) for the following reaction sequence

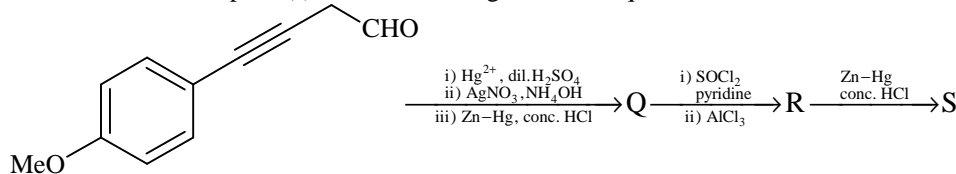

Consider Q, R and S as major products

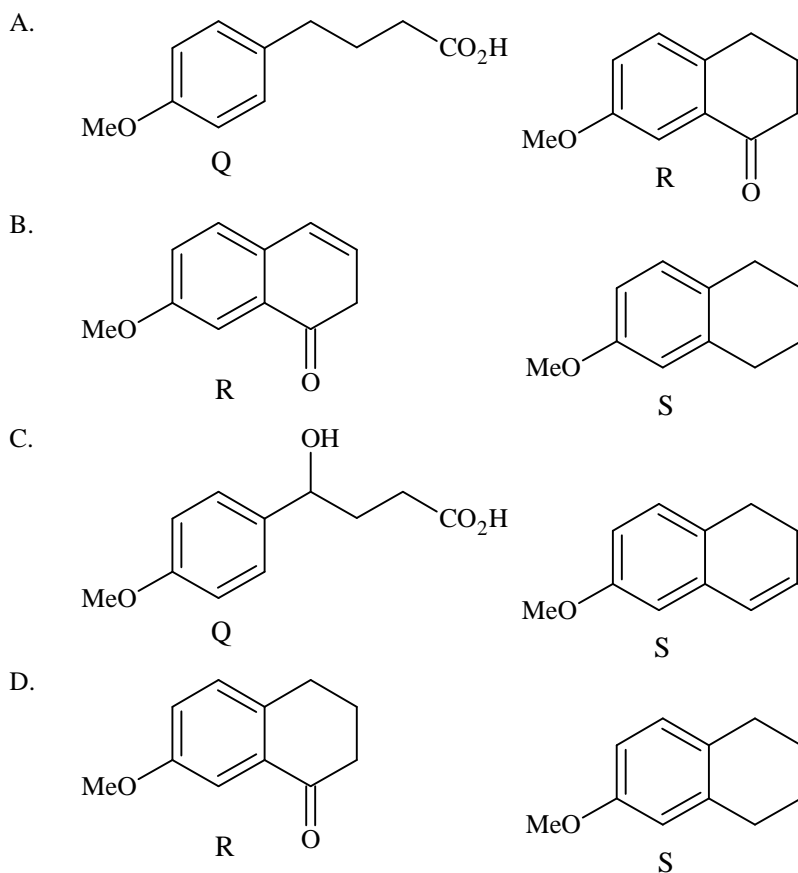

Sol. A, B

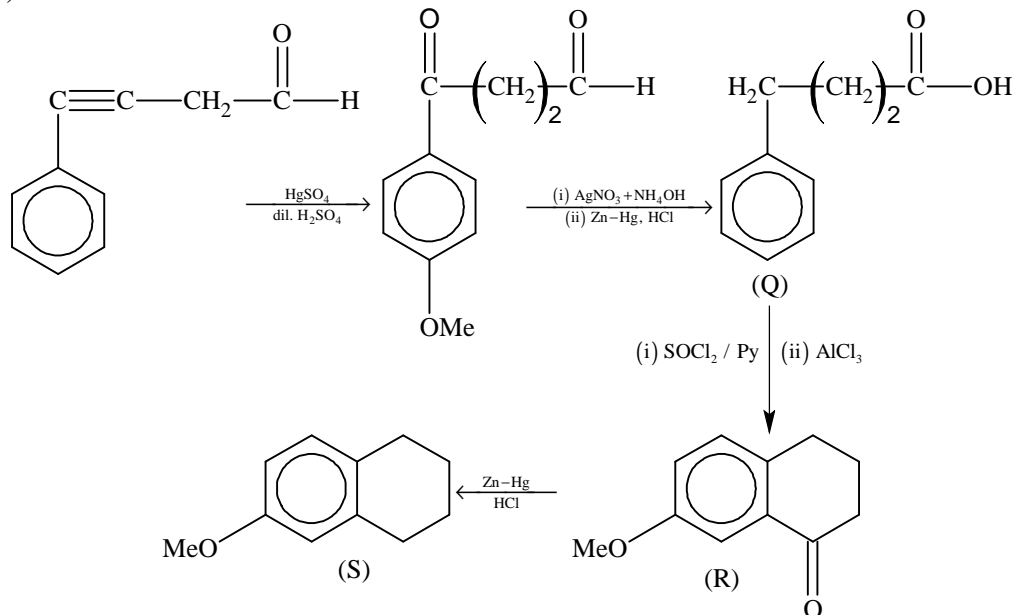

## SECTION 2 (Maximum Marks: 18)

- This section contains **SIX (06)** questions. The answer to each question is a **NUMERICAL VALUE**.
- For each question, enter the correct numerical value of the answer using the mouse and the on-screen virtual numeric keypad in the place designated to enter the answer. If the numerical value has more than two decimal places, **truncate/round-off** the value to **TWO** decimal places.
- Answer to each question will be evaluated according to the following marking scheme:  
*Full Marks* : +3 If **ONLY** the correct numerical value is entered as answer.  
*Zero Marks* : 0 In all other cases

\*Q.1. Total number of isomers, considering both structural and stereoisomers, of cyclic ethers with the molecular formula  $C_4H_8O$  is \_\_\_\_\_

Sol. **10.00**

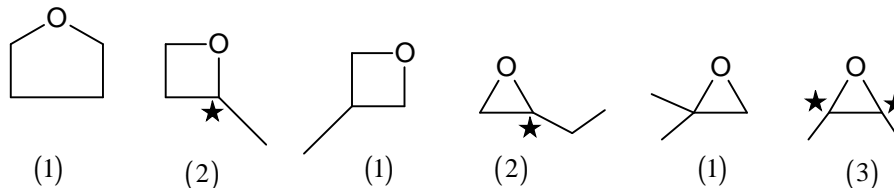

\*Q.2. The mole fraction of urea in an aqueous urea solution containing 900 g of water is 0.05. If the density of the solution is  $1.2 \text{ g cm}^{-3}$ , the molarity of urea solution is \_\_\_\_\_ (Given data: Molar masses of urea and water are  $60 \text{ g mol}^{-1}$  and  $18 \text{ g mol}^{-1}$ , respectively)

Sol. **2.98**

Let mole of urea = x

$$\frac{x}{x + \frac{900}{18}} = 0.05, \quad x = \frac{50}{19}$$

$$\text{Mass of solution} = \frac{50}{19} \times 60 + 900 = \frac{20100}{19}$$

$$\text{Volume of solution} = \frac{20100}{19 \times 1.2} \text{ ml}$$

$$= \frac{20.1}{19 \times 1.2} \text{ litre}$$

$$\text{Molarity} = \frac{\frac{50}{19}}{\frac{20.1}{19 \times 1.2}} = \frac{50 \times 1.2}{20.1} = \frac{60}{20.1} \approx 2.985$$

3. Total number of *cis* N-Mn-Cl bond angles (that is, Mn – N and Mn – Cl bonds in *cis* positions) present in a molecule of *cis*-[Mn(en)<sub>2</sub>Cl<sub>2</sub>] complex is \_\_\_\_\_ (en = NH<sub>2</sub>CH<sub>2</sub>CH<sub>2</sub>NH<sub>2</sub>)

Sol. **6.00**

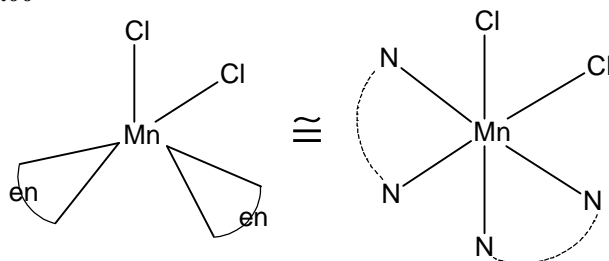

- \*Q. 4. The amount of water produced (in g) in the oxidation of 1 mole of rhombic sulphur by conc.  $\text{HNO}_3$  to a compound with the highest oxidation state of sulphur is \_\_\_\_\_  
(Given data : Molar mass of water =  $18 \text{ g mol}^{-1}$ )

**Sol. 288.00**



$$\text{Mass of H}_2\text{O} = 18 \times 16 = 288 \text{ gram}$$

5. The decomposition reaction  $2\text{N}_2\text{O}_5(\text{g}) \xrightarrow{\Delta} 2\text{N}_2\text{O}_4(\text{g}) + \text{O}_2(\text{g})$  is started in a closed cylinder under isothermal isochoric condition at an initial pressure of 1 atm. After  $Y \times 10^3 \text{ s}$ , the pressure inside the cylinder is found to be 1.45 atm. If the rate constant of the reaction is  $5 \times 10^{-4} \text{ s}^{-1}$ , assuming ideal gas behaviour, the value of **Y** is \_\_\_\_\_

**Sol. 2.30**

Unit of K represent it is first order reaction.

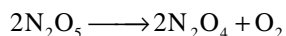

$$t = 0 \quad 1 \quad 0 \quad 0$$

$$t = t \quad 1 - P \quad P \quad P/2$$

$$1 - P + P + \frac{P}{2} = 1.45$$

$$\frac{P}{2} = 0.45, p = 0.9$$

$$t = \frac{2.303}{2 \times 5 \times 10^{-4}} \log \frac{1}{1 - P}$$

$$y \times 10^{-3} = \frac{2.303}{2 \times 5 \times 10^{-4}} \log \frac{1}{1 - 0.9} = \frac{2.303}{2 \times 5 \times 10^{-4}} \log 10$$

$$Y = 2.30$$

- \*Q.6. Total number of hydroxyl groups present in a molecule of the major product **P** is \_\_\_\_\_

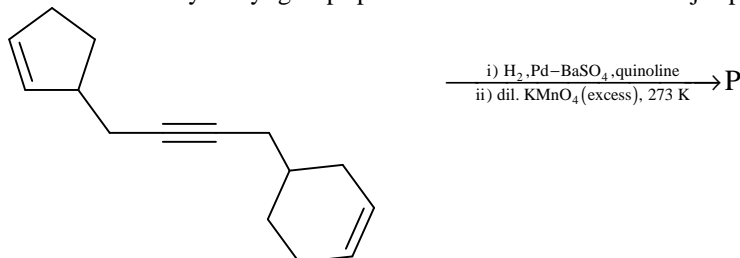

**Sol. 6.00**

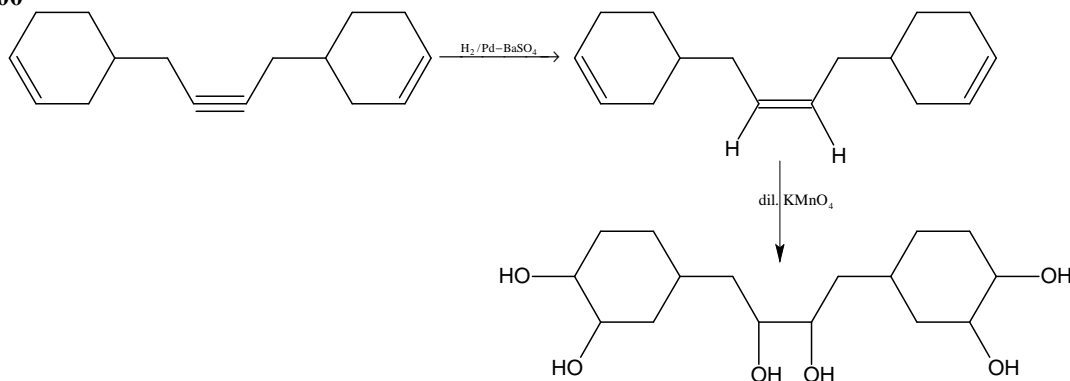

## SECTION 3 (Maximum Marks: 12)

- This section contains **TWO (02)** questions.
- Each List-Match set has **TWO (02)** Multiple Choice Questions.
- Each List-Match set has two lists: **List-I** and **List-II**.
- **List-I** has **Four** entries (I), (II), (III) and (IV) and **List-II** has **Six** entries (P), (Q), (R), (S), (T) and (U).
- **FOUR** options are given in each Multiple Choice Question based on **List-I** and **List-II** and **ONLY ONE** of these four options satisfies the condition asked in the Multiple Choice Question.  
Answer to each question will be evaluated according to the following marking scheme:  
*Full Marks* : +3 If **ONLY** the option corresponding to the correct combination is chosen.  
*Zero Marks* : 0 If none of the options is chosen (i.e. the question is unanswered).  
*Negative Marks* : -1 In all other cases.

Answer the following by appropriately matching the lists based on the information given in the paragraph

- \*Q.1. Consider the Bohr's model of a one-electron atom where the electron moves around the nucleus. In the following, List-I contains some quantities for the  $n^{\text{th}}$  orbit of the atom and List-II contains options showing how they depend on  $n$ .

LIST-I		LIST-II	
(I)	Radius of the $n^{\text{th}}$ orbit	(P)	$\propto n^{-2}$
(II)	Angular momentum of the electron in the $n^{\text{th}}$ orbit	(Q)	$\propto n^{-1}$
(III)	Kinetic energy of the electron in the $n^{\text{th}}$ orbit	(R)	$\propto n^0$
(IV)	Potential energy of the electron in the $n^{\text{th}}$ orbit	(S)	$\propto n^1$
		(T)	$\propto n^2$
		(U)	$\propto n^{1/2}$

Which of the following options has the correct combination considering List-I and List-II?

Options

- A. (III), (P)  
B. (IV), (U)  
C. (III), (S)  
D. (IV), (Q)

Sol. A

Answer the following by appropriately matching the lists based on the information given in the paragraph

- \*Q.2. Consider the Bohr's model of a one-electron atom where the electron moves around the nucleus. In the following, List-I contains some quantities for the  $n^{\text{th}}$  orbit of the atom and List-II contains options showing how they depend on  $n$ .

LIST-I		LIST-II	
(I)	Radius of the $n^{\text{th}}$ orbit	(P)	$\propto n^{-2}$
(II)	Angular momentum of the electron in the $n^{\text{th}}$ orbit	(Q)	$\propto n^{-1}$
(III)	Kinetic energy of the electron in the $n^{\text{th}}$ orbit	(R)	$\propto n^0$
(IV)	Potential energy of the electron in the $n^{\text{th}}$ orbit	(S)	$\propto n^1$
		(T)	$\propto n^2$
		(U)	$\propto n^{1/2}$

Which of the following options has the correct combination considering List-I and List-II?

Options

- A. (I), (T)  
B. (II), (R)  
C. (I), (P)  
D. (II), (Q)

Sol. A

$$\text{Sol(1-2). KE} = \frac{13.6Z^2}{n^2} \text{ eV / atom}$$

$$\text{PE} = \frac{-2 \times 13.6Z^2}{n^2} \text{ eV / atom}$$

$$\text{Radius} = 0.529 \frac{n^2}{Z} \text{ \AA}$$

$$\text{Angular momentum of electron (mvr)} = \frac{nh}{2\pi}$$

Answer the following by appropriately matching the lists based on the information given in the paragraph

3. List-I includes starting materials and reagents of selected chemical reactions. List-II gives structures of compounds that may be formed as intermediate products and/or final products from the reactions of List-I.

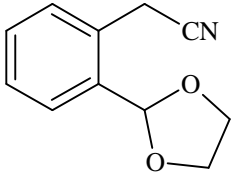
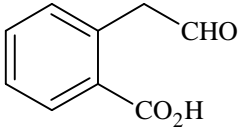
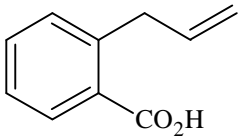
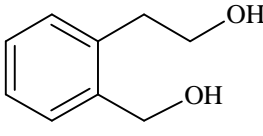
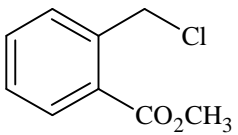
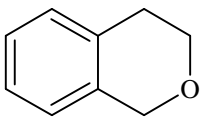
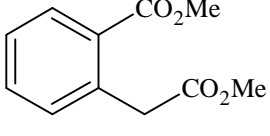
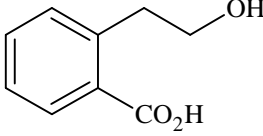
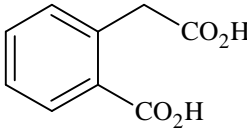
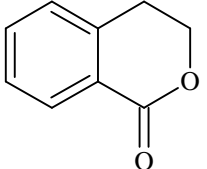
LIST-I		LIST-II		
(I)		$\xrightarrow[\text{iv) conc. H}_2\text{SO}_4]{\text{i) DIBAL-H, ii) dil. HCl, iii) NaBH}_4$	(P)	
(II)		$\xrightarrow[\text{iv) conc. H}_2\text{SO}_4]{\text{i) O}_3, \text{ii) Zn, H}_2\text{O, iii) NaBH}_4$	(Q)	
(III)		$\xrightarrow[\text{iv) conc. H}_2\text{SO}_4]{\text{i) KCN, ii) H}_3\text{O}^+, \Delta, \text{iii) LiAlH}_4$	(R)	
(IV)		$\xrightarrow[\text{ii) conc. H}_2\text{SO}_4]{\text{i) LiAlH}_4}$	(S)	
			(T)	
			(U)	

Which of the following options has the correct combination considering List-I and List-II?

Options

- A. (II), (P), (S), (T)  
 B. (II), (P), (S), (U)  
 C. (I), (S), (Q), (R)  
 D. (I), (Q), (T), (U)

Sol. B

Answer the following by appropriately matching the lists based on the information given in the paragraph

4. List-I includes starting materials and reagents of selected chemical reactions. List-II gives structures of compounds that may be formed as intermediate products and/or final products from the reactions of List-I.

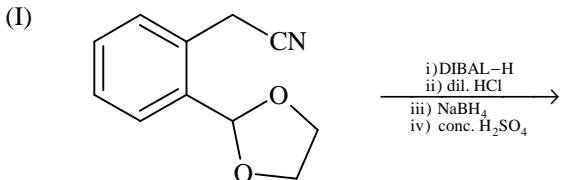
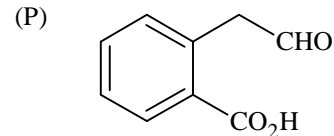
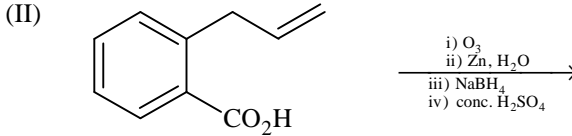
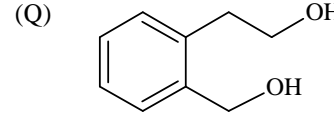
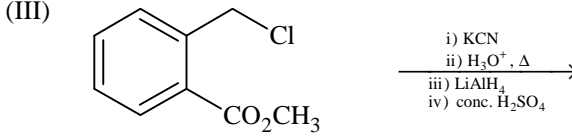
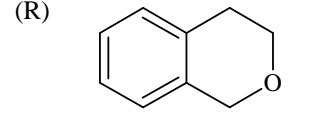
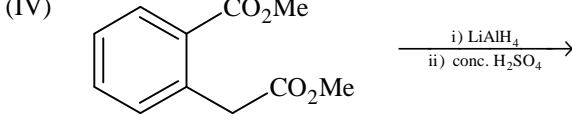
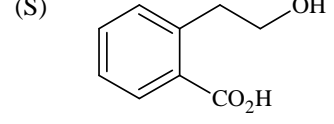
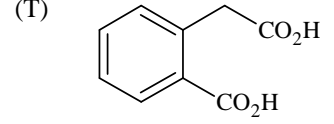
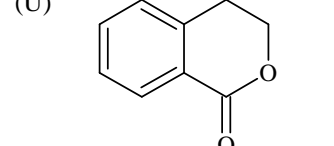
LIST-I	LIST-II
(I) 	(P) 
(II) 	(Q) 
(III) 	(R) 
(IV) 	(S) 
	(T) 
	(U) 

Which of the following options has the correct combination considering List-I and List-II?

Options

- A. (IV), (Q), (U)  
 B. (IV), (Q), (R)  
 C. (III), (S), (R)  
 D. (III), (T), (U)

Sol. B  
 Sol(3-4). (i)

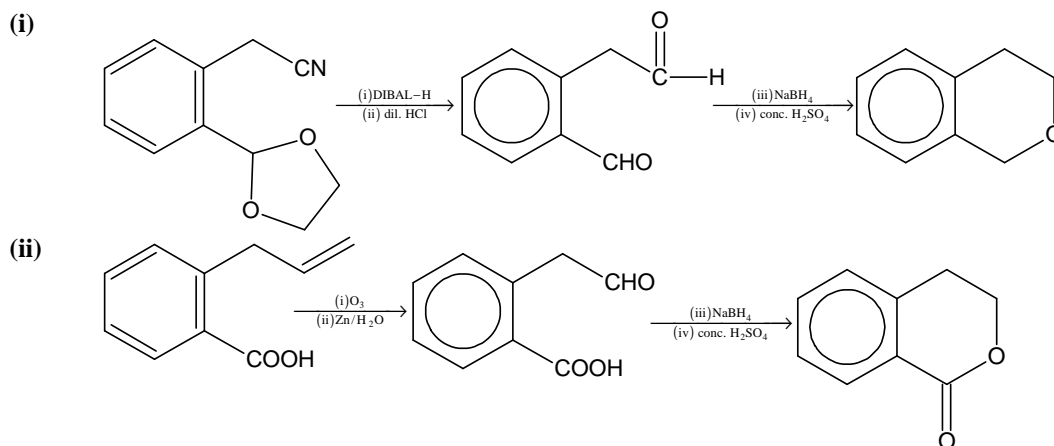

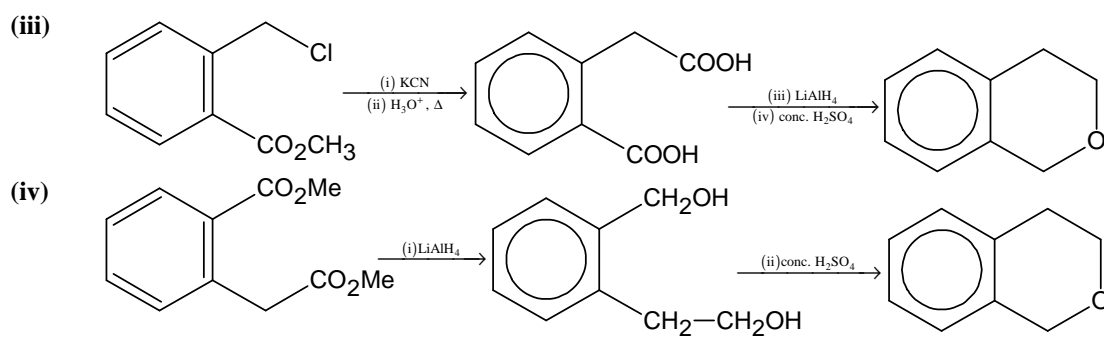

**PART III: MATHEMATICS****Section 1 (maximum marks: 32)**

- This section contains **EIGHT** (08) questions.
- Each question has **FOUR** options **ONE OR MORE THAN ONE** of these four option(s) is(are) correct answer(s).
- For each question, choose the option(s) corresponding to (all) the correct answer(s).
- Answer to each question will be evaluated according to the following marking scheme.
 

Full Marks	: +4	If only (all) the correct option(s) is (are) chosen;
Partial Marks	: +3	If all the four options are correct but <b>ONLY</b> three options are chosen;
Partial marks	: +2	if three or more options are correct but <b>ONLY</b> two options are chosen and both of which are correct;
Partial Marks	: +1	If two or more options are correct but <b>ONLY</b> one option is chosen and it is a correct option;
Zero Marks	: 0	If none of the options is chosen (i.e. the question is unanswered);
Negative Marks	: -1	In all other cases.
- For example, in a question, if (A), (B) and (D) are the **ONLY** three options corresponding to correct answers, then
  - choosing **ONLY** (A), (B) and (D) will get +4 marks;
  - choosing **ONLY** (A) and (B) will get +2 marks;
  - choosing **ONLY** (A) and (D) will get +2 marks;
  - choosing **ONLY** (B) and (D) will get +2 marks;
  - choosing **ONLY** (A) will get +1 marks;
  - choosing **ONLY** (B) will get +1 marks;
  - choosing **ONLY** (C) will get +1 marks;
  - choosing **ONLY** (D) will get +1 marks;
  - choosing no option (i.e. the question is unanswered) will get 0 marks; and
  - choosing any other combination of options will get -1 mark.

Q.1 Three lines

$$L_1 : \vec{r} = \lambda \hat{i}, \lambda \in \mathbb{R}$$

$$L_2 : \vec{r} = \hat{k} + \mu \hat{j}, \mu \in \mathbb{R} \text{ and}$$

$$L_3 : \vec{r} = \hat{i} + \hat{j} + \nu \hat{k}, \nu \in \mathbb{R}$$

are given. For which point(s) Q on  $L_2$  can we find a point P on  $L_1$  and a point R on  $L_3$  so that P, Q and R are collinear?

A.  $\hat{k} - \frac{1}{2} \hat{j}$

B.  $\hat{k} + \frac{1}{2} \hat{j}$

C.  $\hat{k}$

D.  $\hat{k} + \hat{j}$

**Sol.** **A, B**

P.V. of point P,  $\vec{p} = \lambda \hat{i}$

P.V. of point Q,  $\vec{q} = \mu \hat{j} + \hat{k}$

P.V. of point R,  $\vec{r} = \hat{i} + \hat{j} + r \hat{k}$

PQR are collinear. Hence  $x(\overline{PQ}) = y(\overline{PR})$

$$\Rightarrow \frac{x}{y} = \frac{1-\lambda}{-\lambda} = \frac{1}{\mu} = r$$

$$\Rightarrow \vec{q} = \frac{1}{r} \hat{j} + \hat{k} \text{ or } \vec{q} = \frac{\lambda}{\lambda-1} \hat{j} + \hat{k}, \text{ where } r \neq 0, \lambda \neq 0, \frac{\lambda}{\lambda-1} \neq 1$$

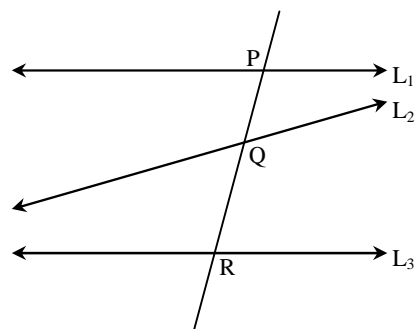

$$\Rightarrow \mu \neq 0, 1.$$

Hence,  $\hat{q} \neq \hat{k}$  or  $\hat{j} + \hat{k}$ .

Q.2 Let  $x \in \mathbb{R}$  and let

$$P = \begin{bmatrix} 1 & 1 & 1 \\ 0 & 2 & 2 \\ 0 & 0 & 3 \end{bmatrix}, Q = \begin{bmatrix} 2 & x & x \\ 0 & 4 & 0 \\ x & x & 6 \end{bmatrix} \text{ and } R = PQP^{-1}$$

Then which of the following options is/are correct?

A. For  $x = 0$ , if  $R \begin{bmatrix} 1 \\ a \\ b \end{bmatrix} = 6 \begin{bmatrix} 1 \\ a \\ b \end{bmatrix}$ , then  $a + b = 5$

B. For  $x = 1$ , there exists a unit vector  $\alpha \hat{i} + \beta \hat{j} + \gamma \hat{k}$  for which  $R \begin{bmatrix} \alpha \\ \beta \\ \gamma \end{bmatrix} = \begin{bmatrix} 0 \\ 0 \\ 0 \end{bmatrix}$

C.  $\det R = \det \begin{bmatrix} 2 & x & x \\ 0 & 4 & 0 \\ x & x & 5 \end{bmatrix} + 8$ , for all  $x \in \mathbb{R}$

D. There exists a real number  $x$  such that  $PQ = QP$

**Sol.** **A, C**

$$R = PQP^{-1}$$

$$\det(R) = \det(PQP^{-1})$$

$$|R| = |PQP^{-1}|$$

$$= |P| \cdot |Q| \cdot |P^{-1}|$$

$$= |P| \cdot |Q| \cdot \frac{1}{|P|}$$

$$= |Q|$$

$$\det(Q) = \begin{vmatrix} 2 & x & x \\ 0 & 4 & 0 \\ x & x & 6 \end{vmatrix} = 4 \begin{vmatrix} 2 & x \\ x & 6 \end{vmatrix}$$

$$= 4(12 - x^2) = 48 - 4x^2.$$

$$\det(R) = \det(Q) = 48 - 4x^2$$

(A) For  $x = 0$

$$PQ = \begin{bmatrix} 1 & 1 & 1 \\ 0 & 2 & 2 \\ 0 & 0 & 3 \end{bmatrix} \begin{bmatrix} 2 & 0 & 0 \\ 0 & 4 & 0 \\ 0 & 0 & 6 \end{bmatrix}$$

$$= \begin{bmatrix} 2 & 4 & 6 \\ 0 & 8 & 12 \\ 0 & 0 & 18 \end{bmatrix}$$

$$P^{-1} = \frac{1}{|P|} (\text{Adj}P)'$$

$$= \frac{1}{6} \begin{bmatrix} 6 & -3 & 0 \\ 0 & 3 & -2 \\ 0 & 0 & 2 \end{bmatrix}$$

$$\begin{aligned}
 R &= PQP^{-1} \\
 &= \begin{bmatrix} 2 & 4 & 6 \\ 0 & 8 & 12 \\ 0 & 0 & 18 \end{bmatrix} \frac{1}{6} \begin{bmatrix} 6 & -3 & 0 \\ 0 & 3 & -2 \\ 0 & 0 & 2 \end{bmatrix} \\
 &= \frac{1}{6} \begin{bmatrix} 12 & 6 & 4 \\ 0 & 24 & 8 \\ 0 & 0 & 36 \end{bmatrix} = \begin{bmatrix} 2 & 1 & \frac{2}{3} \\ 0 & 4 & \frac{4}{3} \\ 0 & 0 & 6 \end{bmatrix}
 \end{aligned}$$

$$\text{Given, } R \begin{bmatrix} 1 \\ a \\ b \end{bmatrix} = 6 \begin{bmatrix} 1 \\ a \\ b \end{bmatrix}$$

$$\Rightarrow (R - 6I) \begin{bmatrix} 1 \\ a \\ b \end{bmatrix} = 0$$

$$\Rightarrow \begin{bmatrix} -4 & 1 & \frac{2}{3} \\ 0 & -2 & \frac{4}{3} \\ 0 & 0 & 0 \end{bmatrix} \begin{bmatrix} 1 \\ a \\ b \end{bmatrix} = 0$$

$$\Rightarrow -4 + a + \frac{2}{3}b = 0 \quad \dots (1)$$

$$-2a + \frac{4}{3}b = 0 \quad \dots (2)$$

From (1) and (2)

$$2a = 4 \Rightarrow a = 2 \text{ and } b = 3$$

So,  $a + b = 5$ .

- (B) For  $x = 1$   
 $\det(R) = 48 - 4x^2 = 48 - 4 = 40$   
 $\det(R) \neq 0$

$$R \begin{bmatrix} \alpha \\ \beta \\ \gamma \end{bmatrix} = \begin{bmatrix} 0 \\ 0 \\ 0 \end{bmatrix}$$

$$\Rightarrow \alpha = \beta = \gamma = 0$$

Hence,  $\alpha\hat{i} + \beta\hat{j} + \gamma\hat{k}$  cannot a unit vector.

$$(C) \det \begin{vmatrix} 2 & x & x \\ 0 & 4 & 0 \\ x & x & 5 \end{vmatrix} + 8$$

$$= 4 \begin{vmatrix} 2 & x \\ x & 6 \end{vmatrix} + 8$$

$$= 4(10 - x^2) + 8$$

$$= 40 - 4x^2 + 8 = 48 - 4x^2.$$

(D)  $PQ = QP$ 

$$\begin{bmatrix} 1 & 1 & 1 \\ 0 & 2 & 2 \\ 0 & 0 & 3 \end{bmatrix} \begin{bmatrix} 2 & x & x \\ 0 & 4 & 0 \\ x & x & 6 \end{bmatrix} = \begin{bmatrix} 2 & x & x \\ 0 & 4 & 0 \\ x & x & 6 \end{bmatrix} \begin{bmatrix} 1 & 1 & 1 \\ 0 & 2 & 2 \\ 0 & 0 & 3 \end{bmatrix}$$

If we equate  $a_{12}$  from both

$$x + 4 + x = 2 + 2x$$

$$\Rightarrow 4 = 2$$

 $\Rightarrow x \in \phi$ , no value exists.Q.3 For non-negative integers  $n$ , let

$$f(n) = \frac{\sum_{k=0}^n \sin\left(\frac{k+1}{n+2}\pi\right) \sin\left(\frac{k+2}{n+2}\pi\right)}{\sum_{k=0}^n \sin^2\left(\frac{k+1}{n+2}\pi\right)}$$

Assuming  $\cos^{-1}x$  takes values in  $[0, \pi]$ , which of the following options is/are correct?

A.  $f(4) = \frac{\sqrt{3}}{2}$

B. If  $\alpha = \tan(\cos^{-1}f(6))$ , then  $\alpha^2 + 2\alpha - 1 = 0$

C.  $\sin(7 \cos^{-1}f(5)) = 0$

D.  $\lim_{n \rightarrow \infty} f(n) = \frac{1}{2}$

**Sol.** A, B, C

$$\begin{aligned} f(x) &= \frac{\sum_{k=0}^n 2 \sin\left(\frac{k+1}{n+2}\pi\right) \sin\left(\frac{k+2}{n+2}\pi\right)}{\sum_{k=0}^n 2 \sin^2\left(\frac{k+1}{n+2}\pi\right)} \\ &= \frac{\sum_{k=0}^n \cos\frac{\pi}{n+2} - \sum_{k=0}^n \cos\left(\frac{2k+3}{n+2}\pi\right)}{\sum_{k=0}^n \left(1 - \cos\left(\frac{2k+2}{n+2}\pi\right)\right)} \\ &= \frac{(n+1)\cos\left(\frac{\pi}{n+2}\right) - \frac{\cos\left(\frac{n+3}{n+2}\pi\right) \cdot \sin\left(\frac{n+1}{n+2}\pi\right)}{\sin\left(\frac{\pi}{n+2}\right)}}{\cos\pi \cdot \sin\left(\frac{n+1}{n+2}\pi\right)} \\ &= \frac{(n+1)\cos\left(\frac{\pi}{n+2}\right) - \frac{\cos\left(\pi + \frac{\pi}{n+2}\right) \cdot \sin\left(\pi - \frac{\pi}{n+2}\right)}{\sin\left(\frac{\pi}{n+2}\right)}}{(n+1) - \frac{\cos\pi \cdot \sin\left(\pi - \frac{\pi}{n+2}\right)}{\sin\left(\frac{\pi}{n+2}\right)}} \end{aligned}$$

$$= \frac{(n+1)\cos\left(\frac{\pi}{n+2}\right) + \cos\left(\frac{\pi}{n+2}\right)}{n+1+1}$$

$$= \frac{(n+2)\cos\left(\frac{\pi}{n+2}\right)}{n+2} = \cos\left(\frac{\pi}{n+2}\right)$$

$$(A) f(4) = \cos\left(\frac{\pi}{4+2}\right) = \cos\left(\frac{\pi}{6}\right) = \frac{\sqrt{3}}{2}$$

$$(B) \alpha = \tan\left(\cos^{-1}\left(\cos\left(\frac{\pi}{8}\right)\right)\right) = \tan\frac{\pi}{8}$$

$$\tan\frac{\pi}{4} = \frac{2\tan\frac{\pi}{8}}{1-\tan^2\frac{\pi}{8}} \Rightarrow 1 = \frac{2\alpha}{1-\alpha^2}$$

$$\Rightarrow \alpha^2 + 2\alpha - 1 = 0.$$

$$(C) \sin\left(7\cos^{-1}\left(\cos\frac{\pi}{7}\right)\right)$$

$$= \sin\left(7 \times \frac{\pi}{7}\right) = \sin\pi = 0.$$

$$(D) \lim_{n \rightarrow \infty} f(n) = \lim_{n \rightarrow \infty} \cos\left(\frac{\pi}{n+2}\right) = \cos(0) = 1$$

Q.4 For  $a \in \mathbb{R}$   $|a| > 1$ , let

$$\lim_{n \rightarrow \infty} \left( \frac{1 + \sqrt[3]{2} + \dots + \sqrt[3]{n}}{n^{7/3} \left( \frac{1}{(an+1)^2} + \frac{1}{(an+2)^2} + \dots + \frac{1}{(an+n)^2} \right)} \right) = 54$$

Then the possible value(s) of  $a$  is/are

- A. 8  
C. 7

- B. -6  
D. -9

**Sol. A, D**

$$\lim_{n \rightarrow \infty} \frac{\sqrt[3]{1} + \sqrt[3]{2} + \dots + \sqrt[3]{n}}{n^{7/3} \left( \frac{1}{(xa+1)^2} + \frac{1}{(xa+2)^2} + \dots + \frac{1}{(xa+n)^2} \right)} = 54$$

$$= \lim_{n \rightarrow \infty} \frac{\sum_{r=1}^n r^{1/3}}{n^{7/3} \left( \sum_{r=1}^n \frac{1}{(na+r)^2} \right)} = \lim_{n \rightarrow \infty} \frac{\sum_{r=1}^n \left( \frac{r}{n} \right)^{1/3}}{\sum_{r=1}^n \left( \frac{1}{\left( a + \frac{r}{n} \right)^2} \right)}$$

$$= \frac{\int_0^1 x^{1/3} dx}{\int_0^1 \frac{dx}{(a+x)^2}} = \frac{\frac{3}{4} x^{4/3} \Big|_0^1}{-\left( \frac{1}{a+x} \right) \Big|_0^1} = \frac{\frac{3}{4}}{-\left( \frac{1}{a+1} - \frac{1}{a} \right)} = 54$$

$$\Rightarrow \frac{3}{4\left(\frac{1}{a(a+1)}\right)} = 54 \Rightarrow a = 8 \text{ or } a = -9$$

Q.5 Let  $f(x) = \frac{\sin \pi x}{x^2}, x > 0$

Let  $x_1 < x_2 < x_3 < \dots < x_n < \dots$  be all the points of local maximum of  $f$  and  $y_1 < y_2 < y_3 < \dots < y_n < \dots$  be all the points of local minimum of  $f$ . Then which of the following options is/are correct?

- A.  $x_1 < y_1$  B.  $|x_n - y_n| > 1$  for every  $n$   
 C.  $x_n \in \left(2n, 2n + \frac{1}{2}\right)$  for every  $n$  D.  $x_{n+1} - x_n > 2$  for every  $n$

Sol. **B, C, D**

$$f(x) = \frac{\sin \pi x}{x^2}$$

$$\Rightarrow f'(x) = \frac{\pi x^2 \cos \pi x - 2x \sin \pi x}{x^4}$$

$$= \frac{2 \cos \pi x \left(\frac{\pi x}{2} - \tan \pi x\right)}{x^3}$$

$$f'(x) = 0 \Rightarrow \cos \pi x = 0 \text{ or } \frac{\pi x}{2} = \tan \pi x$$

$$\Rightarrow \pi x = (2n+1)\frac{\pi}{2} \text{ or } \frac{\pi x}{2} = \tan \pi x$$

$$x = \frac{(2n+1)}{2}, n \in \mathbb{I}$$

from graph, we can see that  $\forall x = \frac{2n+1}{2}$

$\Rightarrow f'(x)$  doesn't change sign so these points are neither local maxima nor local minimum.

$$\text{Similarly, } \forall x : \frac{\pi x}{2} = \tan \pi x$$

Where  $y_n \in (2n-1, 2n - \frac{1}{2}) \forall n = 1, 2, 3, \dots$

and  $x_n \in (2n, 2n + \frac{1}{2}) \forall n = 1, 2, 3, \dots$

$x_{n+1} - y_{n+1} > 1$  and  $y_{n+1} - x_n > 1 \Rightarrow x_{n+1} - x_n > 2$ .

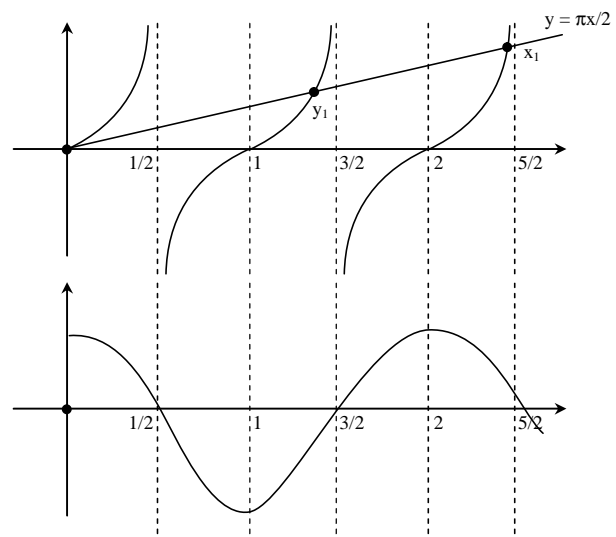

Q.6 Let  $f: \mathbb{R} \rightarrow \mathbb{R}$  be given by  $f(x) = (x-1)(x-2)(x-5)$ . Define

$$F(x) = \int_0^x f(t) dt, x > 0$$

Then which of the following options is/are correct?

- A.  $F(x) \neq 0$  for all  $x \in (0, 5)$   
 B.  $F$  has a local minimum at  $x = 1$   
 C.  $F$  has a local maximum at  $x = 2$   
 D.  $F$  has two local maxima and one local minimum in  $(0, \infty)$

Sol. **A, B, C**

$$F(x) = \int_0^x f(t) dt$$

$$F'(x) = f(x) = (x-1)(x-2)(x-5)$$

$$\Rightarrow x = 1, 5 \text{ is point of local minima for } x > 0$$

$$x = 2 \text{ is point of local maxima for } x > 0$$

$$F(2) = \int_0^2 f(t) dt < 0 \Rightarrow F(x) < 0 \forall x \in (0, 5)$$

Q.7 Let  $P_1 = I = \begin{bmatrix} 1 & 0 & 0 \\ 0 & 1 & 0 \\ 0 & 0 & 1 \end{bmatrix}$ ,  $P_2 = \begin{bmatrix} 1 & 0 & 0 \\ 0 & 0 & 1 \\ 0 & 1 & 0 \end{bmatrix}$ ,  $P_3 = \begin{bmatrix} 0 & 1 & 0 \\ 1 & 0 & 0 \\ 0 & 0 & 1 \end{bmatrix}$

$$P_4 = \begin{bmatrix} 0 & 1 & 0 \\ 0 & 0 & 1 \\ 1 & 0 & 0 \end{bmatrix}, P_5 = \begin{bmatrix} 0 & 0 & 1 \\ 1 & 0 & 0 \\ 0 & 1 & 0 \end{bmatrix}, P_6 = \begin{bmatrix} 0 & 0 & 1 \\ 0 & 1 & 0 \\ 1 & 0 & 0 \end{bmatrix}$$

$$\text{and } X = \sum_{k=1}^6 P_k \begin{bmatrix} 2 & 1 & 3 \\ 1 & 0 & 2 \\ 3 & 2 & 1 \end{bmatrix} P_k^T$$

where  $P_k^T$  denotes the transpose of the matrix  $P_k$ . Then which of the following options is/are correct?

A.  $X - 30I$  is an invertible matrix

B.  $X$  is a symmetric matrix

C. The sum of diagonal entries of  $X$  is 18

D. If  $X \begin{bmatrix} 1 \\ 1 \\ 1 \end{bmatrix} = \alpha \begin{bmatrix} 1 \\ 1 \\ 1 \end{bmatrix}$ , then  $\alpha = 30$

**Sol. B, C, D**

$$P_1 = \begin{bmatrix} 1 & 0 & 0 \\ 0 & 1 & 0 \\ 0 & 0 & 1 \end{bmatrix}, P_2 = \begin{bmatrix} 1 & 0 & 0 \\ 0 & 0 & 1 \\ 0 & 1 & 0 \end{bmatrix}, P_3 = \begin{bmatrix} 0 & 1 & 0 \\ 1 & 0 & 0 \\ 0 & 0 & 1 \end{bmatrix}, P_4 = \begin{bmatrix} 0 & 1 & 0 \\ 0 & 0 & 1 \\ 1 & 0 & 0 \end{bmatrix}, P_5 = \begin{bmatrix} 0 & 0 & 1 \\ 1 & 0 & 0 \\ 0 & 1 & 0 \end{bmatrix}, P_6 = \begin{bmatrix} 0 & 0 & 1 \\ 0 & 1 & 0 \\ 1 & 0 & 0 \end{bmatrix}$$

$$X = \sum P_k \begin{bmatrix} 2 & 1 & 3 \\ 1 & 0 & 2 \\ 3 & 2 & 1 \end{bmatrix} P_k^T$$

$$\text{Let } A = \begin{bmatrix} 2 & 1 & 3 \\ 1 & 0 & 2 \\ 3 & 2 & 1 \end{bmatrix}$$

$$A = A^T.$$

$$X^T = (P_1 A P_1^T + P_2 A P_2^T + \dots + P_6 A P_6^T)^T$$

$$= X$$

So  $X$  is symmetric matrix

$$\text{Let } Q = \begin{bmatrix} 1 \\ 1 \\ 1 \end{bmatrix}$$

$$XQ = P_1 A P_1^T Q + P_2 A P_2^T Q + \dots + P_6 A P_6^T Q$$

$$= P_1 A Q + P_2 A Q + \dots + P_6 A Q$$

$$= (P_1 + P_2 + \dots + P_6) A Q, A Q = \begin{bmatrix} 6 \\ 3 \\ 6 \end{bmatrix}$$

$$= \begin{bmatrix} 2 & 2 & 2 \\ 2 & 2 & 2 \\ 2 & 2 & 2 \end{bmatrix} \begin{bmatrix} 6 \\ 3 \\ 6 \end{bmatrix} = \begin{bmatrix} 30 \\ 30 \\ 30 \end{bmatrix} = 30Q$$

$$XQ = 30Q \Rightarrow (X - 30I)Q = 0$$

So,  $|X - 30I| = 0$ , has non-trivial solution.

So, not invertible.

Where trace  $(P_k A P'_k) = 3$

$$\Rightarrow \text{Trace } X = 3 \times 6 = 18.$$

Q.8 Let  $f: \mathbb{R} \rightarrow \mathbb{R}$  be a function. We say that  $f$  has

PROPERTY 1 if  $\lim_{h \rightarrow 0} \frac{f(h) - f(0)}{\sqrt{|h|}}$  exists and is finite, and

PROPERTY 2 if  $\lim_{h \rightarrow 0} \frac{f(h) - f(0)}{h^2}$  exists and is finite.

Then which of the following options is/are correct?

A.  $f(x) = x|x|$  has PROPERTY 2

B.  $f(x) = \sin x$  has PROPERTY 2

C.  $f(x) = |x|$  has PROPERTY 1

D.  $f(x) = x^{2/3}$  has PROPERTY 1

**Sol. C, D**

(A)  $f(x) = x|x|$

$$= \lim_{h \rightarrow 0} \frac{h|h|}{h^2}$$

$$\lim_{h \rightarrow 0} \frac{|h|}{h} \text{ does not exist.}$$

(B)  $f(x) = \sin x$

$$\lim_{h \rightarrow 0} \frac{\sin h - 0}{h^2} \text{ does not exist.}$$

(C)  $f(x) = |x|$

$$\lim_{h \rightarrow 0} \frac{|h| - 0}{\sqrt{|h|}} = 0.$$

(D)  $f(x) = x^{2/3}$

$$\lim_{h \rightarrow 0} \frac{h^{2/3}}{\sqrt{|h|}} = 0.$$

### Section 2 (Maximum Marks: 18)

- This section contains **SIX (06)** questions. The answer to each question is a **NUMERICAL VALUE**.
- For each question, enter the correct numerical value of the answer using the mouse and the on-screen virtual numeric keypad in the place designated to enter the answer. If the numerical value has more than two decimal places, **truncate/round-off** the value to **TWO** decimal places.
- Answer to each question will be evaluated according to the following marking scheme.  
Full Marks : +3 If only the correct numerical value is entered.  
Zero Marks : 0 In all other cases.

Q.1 The value of the integral

$$\int_0^{\pi/2} \frac{3\sqrt{\cos \theta}}{(\sqrt{\cos \theta} + \sqrt{\sin \theta})^5} d\theta \text{ equals } \underline{\hspace{2cm}}$$

**Sol.** 0.50

$$\begin{aligned}
 I &= \int_0^{\pi/2} \frac{3\sqrt{\cos \theta} \, d\theta}{(\sqrt{\cos \theta} + \sqrt{\sin \theta})^5} \\
 &= \int_0^{\pi/2} \frac{3\sqrt{\sin \theta}}{(\sqrt{\cos \theta} + \sqrt{\sin \theta})^5} \, d\theta \\
 \Rightarrow 2I &= 3 \int_0^{\pi/2} \frac{d\theta}{(\sqrt{\cos \theta} + \sqrt{\sin \theta})^4} = \int_0^{\pi/2} \frac{3 \, d\theta}{\cos^2 \theta (1 + \sqrt{\tan \theta})^4} \\
 \Rightarrow I &= \frac{3}{2} \int_0^{\pi/2} \frac{\sec^2 \theta \, d\theta}{(1 + \sqrt{\tan \theta})^4}
 \end{aligned}$$

$$\text{Let } 1 + \sqrt{\tan \theta} = t \Rightarrow \frac{1}{2\sqrt{\tan \theta}} \sec^2 \theta \, d\theta = dt$$

$$\begin{aligned}
 I &= \frac{3}{2} \int_1^{\infty} \frac{2(t-1)}{t^4} \, dt = \frac{3}{2} \left[ \frac{2}{-2t^2} + \frac{2}{3t^3} \right]_1^{\infty} \\
 &= \frac{3}{2} \left( \frac{2}{2} - \frac{2}{3} \right) = \frac{1}{2} = 0.5
 \end{aligned}$$

Q.2 Let  $\vec{a} = 2\hat{i} + \hat{j} - \hat{k}$  and  $\vec{b} = \hat{i} + 2\hat{j} + \hat{k}$  be two vectors. Consider a vector  $\vec{c} = \alpha\vec{a} + \beta\vec{b}$ ,  $\alpha, \beta \in \mathbb{R}$ . If the projection of  $\vec{c}$  on the vector  $(\vec{a} + \vec{b})$  is  $3\sqrt{2}$ , then the minimum value of  $(\vec{c} - (\vec{a} \times \vec{b})) \cdot \vec{c}$  equals \_\_\_\_\_

**Sol.** 18.00

$$\begin{aligned}
 \frac{\vec{c} \cdot (\vec{a} + \vec{b})}{|\vec{a} + \vec{b}|} &= 3\sqrt{2} \\
 \Rightarrow \frac{\alpha \vec{a} \cdot \vec{a} + \beta \vec{b} \cdot \vec{b} + (\alpha + \beta) \vec{a} \cdot \vec{b}}{3\sqrt{2}} &= 3\sqrt{2} \\
 \Rightarrow 6\alpha + 6\beta + (\alpha + \beta)3 &= 18 \\
 \Rightarrow \alpha + \beta &= 2 \\
 (\vec{c} - (\vec{a} \times \vec{b})) \cdot \vec{c} &= \alpha^2 |\vec{a}|^2 + \beta^2 |\vec{b}|^2 + 2\alpha\beta \vec{a} \cdot \vec{b} - (\vec{a} \times \vec{b}) \cdot \vec{c} \\
 &= 6\alpha^2 + 6\beta^2 + 6\alpha\beta \quad (\text{as } \vec{c} \text{ is linearly dependent on } \vec{a} \text{ \& } \vec{b}) \\
 &= 6[(\alpha + \beta)^2 - \alpha\beta], \quad \max \alpha\beta = 1 \\
 \Rightarrow \min. (\vec{c} - (\vec{a} \times \vec{b})) \cdot \vec{c} &= 18
 \end{aligned}$$

\*Q.3 Five persons A, B, C, D and E are seated in a circular arrangement. If each of them is given a hat of one of the three colours red, blue and green, then the number of ways of distributing the hats such that the persons seated in adjacent seats get different coloured hats is \_\_\_\_\_

**Sol.** 30.00

Maximum number of hats of same colour are 2 and minimum colour required are 3. So, the selection of hats will have to be of the type AABBC

${}^3C_1$  ways to select hat having single colour. Then distribute that single hat in  ${}^5C_1$  ways.  ${}^2C_1$  ways to distribute hat to adjacent person, after that alternate coloured hat will be given so  $3 \times 5 \times 2 = 30$

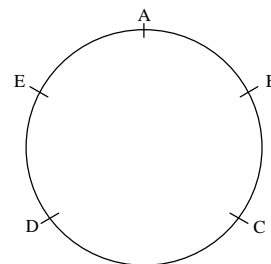

Q.4 Suppose  $\det \begin{bmatrix} \sum_{k=0}^n k & \sum_{k=0}^n {}^n C_k k^2 \\ \sum_{k=0}^n {}^n C_k k & \sum_{k=0}^n {}^n C_k 3^k \end{bmatrix} = 0$  holds for some positive integer n. Then  $\sum_{k=0}^n \frac{{}^n C_k}{k+1}$  equals. \_\_\_\_\_

Sol. 6.20

$$\begin{aligned} & \left| \begin{array}{cc} \sum_{k=0}^n k & \sum_{k=0}^n {}^n C_k k^2 \\ \sum_{k=0}^n {}^n C_k k & \sum_{k=0}^n {}^n C_k 3^k \end{array} \right| = 0 \\ \Rightarrow & \left| \begin{array}{cc} \frac{n(n+1)}{2} & n(n+1)2^{n-2} \\ n 2^{n-1} & 4^n \end{array} \right| = 0 \\ \Rightarrow & n(n+1)2^{n-1} \left| \begin{array}{cc} \frac{1}{2} & 2^{n-2} \\ n & 2^{n+1} \end{array} \right| = 0 \\ \Rightarrow & n(n+1)2^{2n-3} \left| \begin{array}{cc} \frac{1}{2} & 1 \\ n & 8 \end{array} \right| = 0 \\ \Rightarrow & n = 0, -1, 4 \Rightarrow n = 4 \\ & \sum_{k=0}^4 \frac{{}^4 C_k}{k+1} = \sum_{k=0}^4 \frac{1}{5} {}^5 C_{k+1} = \frac{1}{5} (2^5 - 1) = \frac{31}{5} = 6.2 \end{aligned}$$

\*Q.5 Let  $|x|$  denote the number of elements in a set X. Let  $S = \{1, 2, 3, 4, 5, 6\}$  be a sample space, where each element is equally likely to occur. If A and B are independent events associated with S, then the number of ordered pairs (A, B) such that  $1 \leq |B| < |A|$ , equals \_\_\_\_\_

Sol. 422.00

Let  $|A| = x$ ,  $|B| = y$ ,  $|A \cap B| = P$ , then  $\frac{P}{6} = \frac{x}{6} \cdot \frac{y}{6} \Rightarrow 6P = xy$

If  $P = 1 \Rightarrow$  (i)  $x = 6$ ,  $y = 1 \Rightarrow {}^6C_6 \cdot {}^6C_1 = 6$

or  $\Rightarrow$  (ii)  $x = 3$ ,  $y = 2 \Rightarrow {}^6C_3 \cdot {}^3C_1 \cdot {}^3C_1 = 180$

If  $P = 2 \Rightarrow$  (i)  $x = 6$ ,  $y = 2 \Rightarrow {}^6C_6 \cdot {}^6C_2 = 15$

or (ii)  $x = 4$ ,  $y = 3 \Rightarrow {}^6C_4 \cdot {}^4C_2 \cdot {}^2C_1 = 180$

If  $P = 3 \Rightarrow x = 6$ ,  $y = 3 \Rightarrow {}^6C_6 \cdot {}^6C_3 = 20$

If  $P = 4 \Rightarrow x = 6$ ,  $y = 4 \Rightarrow {}^6C_6 \cdot {}^6C_4 = 15$

If  $P = 5 \Rightarrow x = 6$ ,  $y = 5 \Rightarrow {}^6C_6 \cdot {}^6C_5 = 6$

Hence total number of ordered pairs (A, B) = 422.

\*Q.6 The value of  $\sec^{-1}\left(\frac{1}{4}\sum_{k=0}^{10}\sec\left(\frac{7\pi}{12}+\frac{k\pi}{2}\right)\sec\left(\frac{7\pi}{12}+\frac{(k+1)\pi}{2}\right)\right)$  in the interval  $\left[-\frac{\pi}{4}, \frac{3\pi}{4}\right]$  equals \_\_\_\_\_

**Sol. 0.00**

$$\begin{aligned} & \sec^{-1}\left(\frac{1}{4}\sum_{k=0}^{10}\sec\left(\frac{7\pi}{12}+\frac{k\pi}{2}\right)\sec\left(\frac{7\pi}{12}+\frac{(k+1)\pi}{2}\right)\right) \\ &= \sec^{-1}\left(-\frac{1}{4}\sum_{k=0}^{10}\sec\left(\frac{7\pi}{12}+\frac{k\pi}{2}\right)\operatorname{cosec}\left(\frac{7\pi}{12}+\frac{k\pi}{2}\right)\right) \\ &= \sec^{-1}\left(-\frac{1}{2}\sum_{k=0}^{10}\frac{1}{\sin\left(\frac{7\pi}{6}\right)\cdot(-1)^k}\right) \\ &= \sec^{-1}\left(-\frac{1}{2}\frac{1}{\sin\left(\frac{7\pi}{6}\right)}\right) = \sec^{-1}(1) = 0. \end{aligned}$$

### Section 3 (Maximum Marks: 12)

- This section contains **TWO (02)** List-Match Sets.
- Each List-Match set has **TWO(02)** Multiple Choice Questions.
- Each List-Match set has two lists: **List-I** and **List-II**.
- **List-I** has **Four** entries (I), (II), (III) and (IV) and **List-II** has **Six** entries (P), (Q), (R), (S), (T) and (U).
- **FOUR** options are given in each Multiple Choice Question based On **List-I** and **List-II** and **ONLY ONE** of these four options satisfies the condition asked in the Multiple Choice Question.
- Answer to each question will be evaluated according to the following marking scheme:  
 Full Marks : +3 If **ONLY** the option corresponding to correct combination is chosen;  
 Zero Marks : 0 If none of the options is chosen (i.e., the question is unanswered);  
 Zero Marks : -1 In all other cases.

**Answer the following by appropriately matching the lists based on the information given in the paragraph**

Let  $f(x) = \sin(\pi \cos x)$  and  $g(x) = \cos(2\pi \sin x)$  be two functions defined for  $x > 0$ . Define the following sets whose elements are written in the increasing order:

$$X = \{x : f(x) = 0\}, Y = \{x : f'(x) = 0\},$$

$$Z = \{x : g(x) = 0\}, W = \{x : g'(x) = 0\}$$

List – I contains the set X, Y, Z and W. List – II contains some information regarding these sets.

**List – I**

- (I) X  
(II) Y  
(III) Z  
(IV) W

**List – II**

- (P)  $\supseteq \left\{\frac{\pi}{2}, \frac{3\pi}{2}, 4\pi, 7\pi\right\}$   
 (Q) an arithmetic progression  
 (R) NOT an arithmetic progression  
 (S)  $\supseteq \left\{\frac{\pi}{6}, \frac{7\pi}{6}, \frac{13\pi}{6}\right\}$   
 (T)  $\supseteq \left\{\frac{\pi}{3}, \frac{2\pi}{3}, \pi\right\}$   
 (U)  $\supseteq \left\{\frac{\pi}{6}, \frac{3\pi}{4}\right\}$





$$\frac{1}{2} \cdot 12 = \frac{5}{\frac{24}{5}} = \frac{5}{4}$$

Common tangent of  $C_1C_3$  :  $C_1 - C_3 = 0$  (as they touch each other)

$$\Rightarrow \frac{18}{5}x + \frac{24}{5}y + 18 = 0$$

$$\text{or } 3x + 4y + 5 = 0$$

Tangent to  $x^2 = 8\alpha y$  is  $x = Py + \frac{2\alpha}{P}$

$$\text{comparing } \Rightarrow \frac{3}{1} = \frac{4}{-P} = \frac{15}{-\frac{2\alpha}{P}}$$

$$\Rightarrow P = -\frac{4}{3} \Rightarrow \frac{-15P}{2\alpha} = 3 \Rightarrow \alpha = \frac{10}{3}$$

- $\Rightarrow$  I - (P)
- II - (Q)
- III - (R)
- IV - (U)